



Data Sheet

MI-ComPAC

DC-DC Switchers

50 to 300 Watts

1 to 3 outputs



Features

- Inputs: 28 Vdc and 270 Vdc
- Transient protection: 28 Vdc per MIL-STD-704A-F, MIL-STD-1275A/B/D and DO-160E, 270 Vdc per MIL-STD-704D/E/F
- One, two, or three outputs
- Outputs from 2 to 48 Vdc
- Up to 5 W/in³
- High efficiency
- Remote sense
- ZCS power architecture
- Low noise FM control
- MIL-STD-461C/D/E EMI compliance
- Reverse polarity protection

Product Highlights

The MI-ComPAC is a complete single, dual, or triple output DC-DC power supply that delivers up to 300 W from inputs of 28 Vdc or 270 Vdc.

The MI-ComPAC meets the conducted emissions and conducted susceptibility specifications of MIL-STD-461C/D/E and offers complete input transient, surge, and spike protection to the most severe levels of MIL-STD-1275, MIL-STD-704 and DO-160E.

Reverse polarity protection and over / undervoltage lockout provide additional safeguards against potentially damaging line conditions. The MI-ComPAC also features a master disable.

Packaging Options

Conduction Cooled Models Available Add "-CC" to the end of the part number. (Consult factory for details.)
Extended heat sink available add "-H1" to end of part number.

MI-ComPAC Configuration Chart

Configuration	Output Power	# of Modules	Dimensions
Single Output			
MI-LC	50 – 100 W	1	8.6" x 2.5" x 0.99" (218,4 x 63,5 x 25,2 mm)
MI-MC	150 – 200 W	2	8.6" x 4.9" x 0.99" (218,4 x 124,5 x 25,2 mm)
MI-NC	300 W	3	8.6" x 7.3" x 0.99" (218,4 x 185,4 x 25,2 mm)
Dual Output			
MI-PC	100 – 200 W	2	8.6" x 4.9" x 0.99" (218,4 x 124,5 x 25,2 mm)
MI-QC	200 – 300 W	3	8.6" x 7.3" x 0.99" (218,4 x 185,4 x 25,2 mm)
Triple Output			
MI-RC	150 – 300 W	3	8.6" x 7.3" x 0.99" (218,4 x 185,4 x 25,2 mm)

Input Voltage

Nominal	Range	Brownout ^[a]	Transient ^[b]
2 = 28 V	18 – 50 V	16	60
6 = 270 V	125 – 400 V	n/a	475

^[a] Brownout voltage for output power derated to 75% of maximum

^[b] Transient voltage for one second

Output Voltage

Z = 2 V	T = 6.5 V ^[c]	N = 18.5 V
Y = 3.3 V	R = 7.5 V ^[c]	3 = 24 V
0 = 5 V	M = 10 V	L = 28 V
X = 5.2 V	1 = 12 V	J = 36 V
W = 5.5 V	P = 13.8 V	K = 40 V
V = 5.8 V	2 = 15 V	4 = 48 V

^[c] 75 W maximum module power for 28 V input voltage

Product Grade Temps. °C

Grade	Operating	Storage
I =	-40 to +85	-55 to +100
M =	-55 to +85	-65 to +100

Temperatures apply to product case.

Output Power/Current

V _{OUT} ≥ 5 V	V _{OUT} < 5 V
Y = 50 W	Y = 10 A
X = 75 W	X = 15 A
W = 100 W	W = 20 A
V = —	V = 30 A

Output Power/Current

V _{OUT} ≥ 5 V	V _{OUT} < 5 V
V = 150 W	V = 30 A
U = 200 W	U = —
S = 300 W	S = 60 A

Output Power/Current

V _{OUT} ≥ 5 V	V _{OUT} < 5 V
S = 300 W	S = —
P = —	P = 90 A

MI-COMPAC SPECIFICATIONS

(typical at $T_{BP} = 25^{\circ}\text{C}$, nominal line and 75% load, unless otherwise specified)

■ INPUT SPECIFICATIONS

Parameter	Min	Typ	Max	Unit	Notes
28 Vdc input modules					
Steady state input	18	28	50	Vdc	
Low line lockout			17.5	Vdc	Automatic recovery
Input spike limit	-600		+600	Vdc	10 μs , 50 Ω per MIL-STD-704A
	-250		+250	Vdc	70 μs , 15 mJ per MIL-STD-1275A/B/D
Input surge limit			100	Vdc	50 ms, 0.5 Ω per MIL-STD-1275A/B/D
			80	Vdc	100 ms per DO-160E, Section 16, Power Input, Category Z
Overvoltage shut down	50			Vdc	100 ms automatic recovery
Reverse polarity protection					Shunt diode: input fuse required
Recommended fuse			10 ^[a]	Amps	F03A type
270 Vdc input modules					
Steady state input	125	270	400	Vdc	
Low line lockout			125	Vdc	Automatic recovery
Input spike limit			+800	Vdc	10 μs , 50 Ω
	-600		+600	Vdc	100 μs , 15 mJ
Input surge limit			500	Vdc	100 ms, 0.5 Ω
Overvoltage shut down	400			Vdc	100 μs automatic recovery
Reverse polarity protection					Shunt diode: input fuse required
Recommended fuse			2 ^[a]	Amps	F03A type
All models					
No load power dissipation		1.5 ^[a]	2 ^[a]	Watts	
Master disable input current ^[b] (Absolute max., 20 mA)	4			mA	Sink; disables all outputs
Inrush current		110	125	%, IIN	Steady state IIN, 10 ms

^[a] Per internal module configuration

^[b] Multiply minimum x 2 for 2-ups and x 3 for 3-ups

■ OUTPUT SPECIFICATIONS

Parameter	Min	Typ	Max	Unit	Notes
Set point accuracy		0.5	1.0	% Vnom	
Load / line regulation		0.2	0.5	% Vnom	LL to HL, NL to 10%
		0.05	0.2	% Vnom	LL to HL, 10% to FL
Output temperature drift		0.01	0.02	%/°C	
Output noise – p-p		1.0	1.5	% Vnom	Whichever is greater; 20 MHz BW
		100	150	mV	
Output voltage trimming ^[c]	50		110	% Vnom	
Remote sense compensation	0.5			Vdc	
OVP set point	115	125	135	% Vnom	Latching
Current limit	105		125	% Inom	Auto restart
Short circuit current ^[d]	20		130	% Inom	

^[c] 10 V, 12 V, and 15 V outputs, standard trim range $\pm 10\%$. Consult factory for wider trim range

^[d] Output ranges of 5 V or less incorporate foldback current limiting, outputs of 10 V and above incorporate straight line current limiting

MI-COMPAC SPECIFICATIONS (CONT.)

■ THERMAL CHARACTERISTICS

Parameter	Min	Typ	Max	Unit	Notes
Efficiency		81		%	
Operating temperature, case			+85	°C	See product grade
Storage temperature			+100	°C	See product grade
Shut down temperature	+90	+95	+105	°C	Cool and recycle power to restart

■ ISOLATION CHARACTERISTICS

Parameter	Min	Typ	Max	Unit	Notes
Input to output	4,242			Vrms	1 minute
Input to case					
28 Vdc input	2,121			Vrms	1 minute
270 Vdc input	2,500			Vrms	1 minute
Output to case	500			Vrms	1 minute

■ MECHANICAL SPECIFICATIONS

Parameter	Min	Typ	Max	Unit	Notes
Weight					
1 Up		1.2 (544)		lbs. (Grams)	
2 Up		2.4 (1248)		lbs. (Grams)	
3 Up		3.6 (1633)			

■ EMC CHARACTERISTICS; MIL-STD-461C/D/E

Parameter	Notes
Input power leads	
Conducted emissions	CE01, CE03, CE07 MIL-STD-461C — 1-up
	CE101, CE102 MIL-STD-461D — 1-up
	CE101 MIL-STD-461E — 2-up & 3-up
Conducted susceptibility	CS01, CS02, CS06 MIL-STD-461C — 1-up
	CS101, CS114, CS116 MIL-STD-461D — 1-up
	CS101, CS114, CS116 MIL-STD-461E — 2-up & 3-up

■ THERMAL CONSIDERATIONS

Parameter	Standard Units			With Optional Heat Sink ^[a]		
	1-Up	2-Up	3-Up	1-Up	2-Up	3-Up
Thermal Impedance — Case-to-Air (°C/W)						
Free Air (Horizontal)	3.6	1.7	1.4	2.1	1.3	1.0
Forced convection through heat sink fins						
50 LFM	2.7	1.4	1.3	1.5	1.1	0.9
100 LFM	2.3	1.3	1.1	1.2	0.9	0.7
250 LFM	1.6	1.0	0.8	0.7	0.5	0.4
500 LFM	1.2	0.7	0.6	0.4	0.3	0.3
750 LFM	0.9	0.5	0.5	0.3	0.2	0.2
1000 LFM	0.8	0.4	0.4	0.2	0.2	0.2

- Thermal impedance, chassis-to-air, is provided for 1-up, 2-up and 3-up MI-ComPAC package configurations as a function of airflow.
- Case temperature = (total power dissipated x thermal impedance) + ambient temperature.
- Watts dissipated per output = (output power ÷ efficiency) – output power.

[a] To order optional heat sink add –H1 to part number

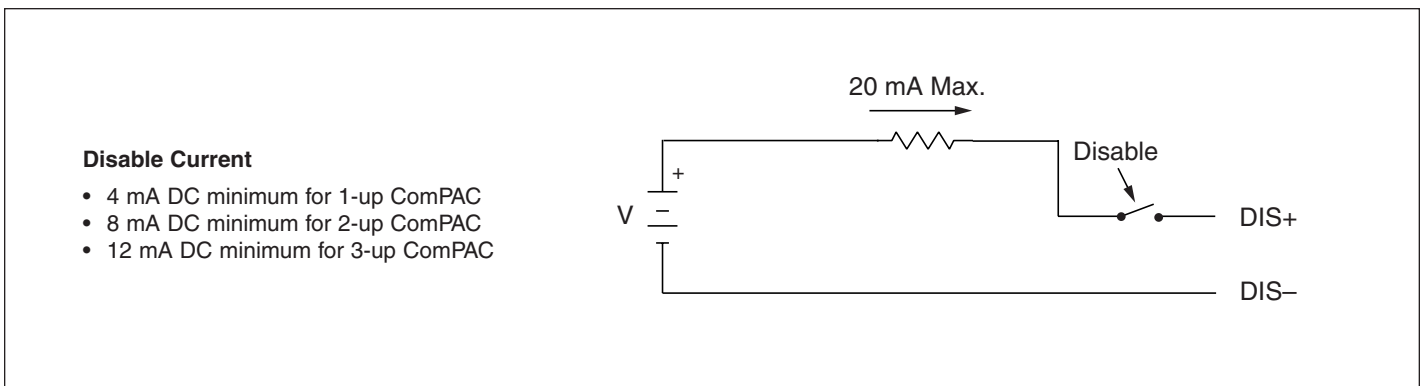

Figure 1 — Disable circuit; The MI-ComPAC incorporates an optically isolated master disable input which will shut down the MI-ComPAC when a current is driven through the disable terminals.

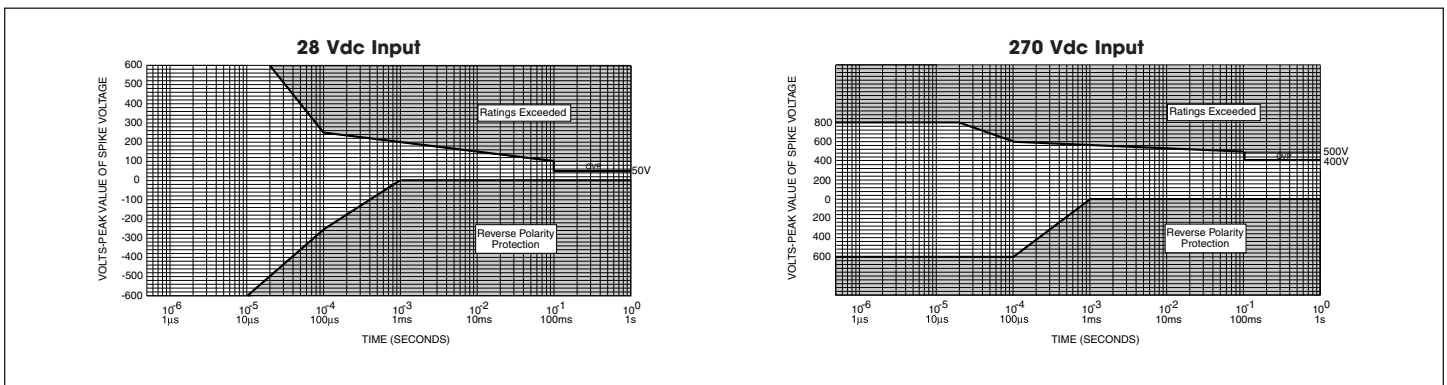
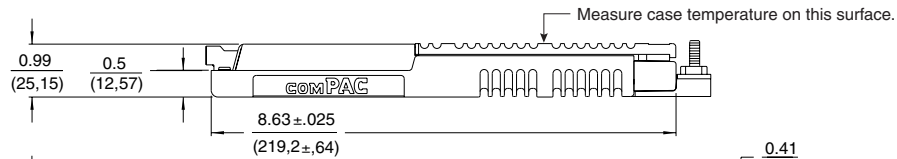

Figure 2 — Long term safe operating area curves; 1% duty cycle maximum, for short duration transient capability refer to specifications

MECHANICAL DRAWINGS

ALL MODELS

INPUTS	
1	Ground
2	-Input
3	+Input
4	Disable-
5	Disable+
OUTPUTS	
A	+Output
B	+Sense
C	Trim
D	-Sense
E	-Output



Standard Heat sink

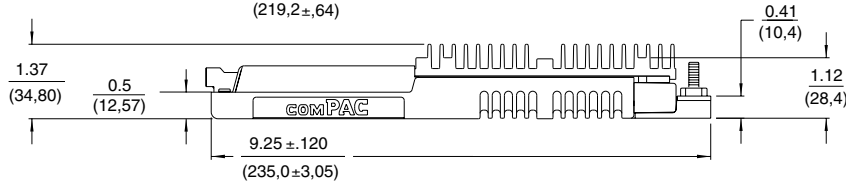

Optional heat sink (H1)

LC SERIES

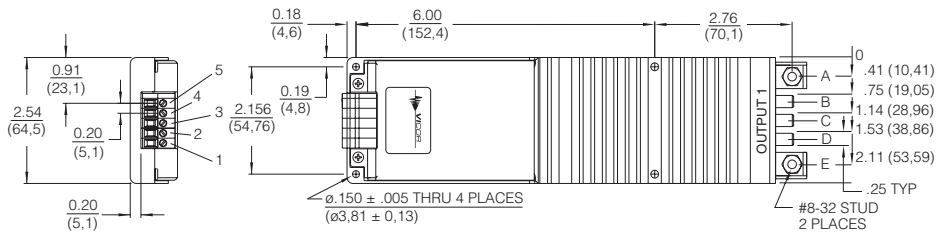

MC, PC SERIES

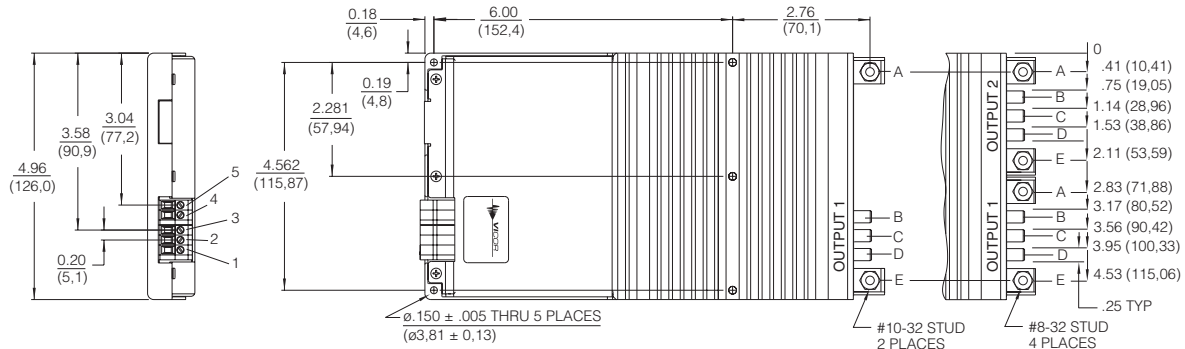

NC, QC, RC Series

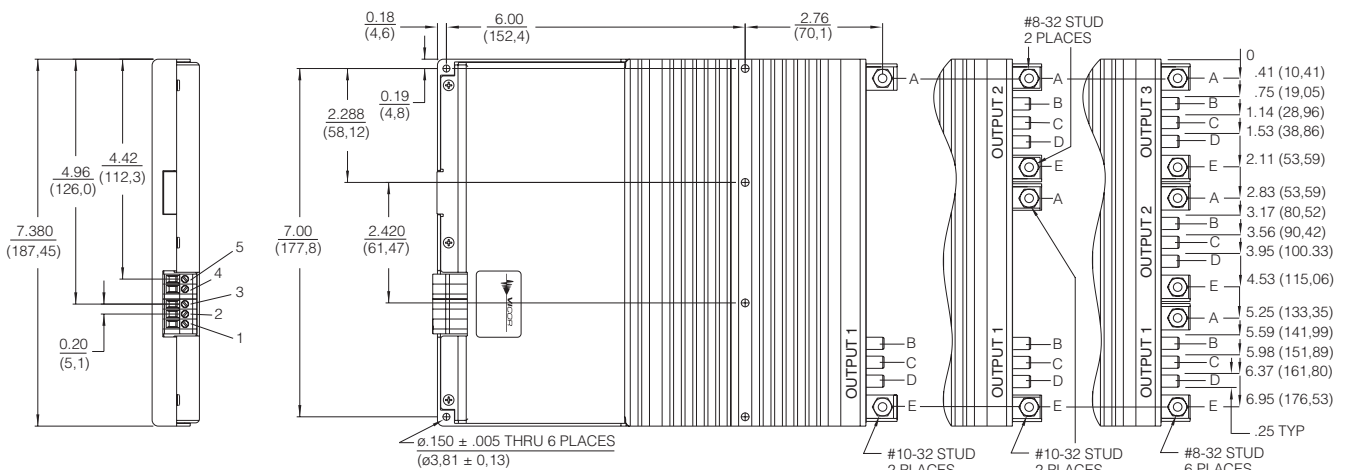

Warranty

Vicor products are guaranteed for two years from date of shipment against defects in material or workmanship when in normal use and service. This warranty does not extend to products subjected to misuse, accident, or improper application or maintenance. Vicor shall not be liable for collateral or consequential damage. This warranty is extended to the original purchaser only.

EXCEPT FOR THE FOREGOING EXPRESS WARRANTY, VICOR MAKES NO WARRANTY, EXPRESS OR IMPLIED, INCLUDING, BUT NOT LIMITED TO, THE WARRANTY OF MERCHANTABILITY OR FITNESS FOR A PARTICULAR PURPOSE.

Vicor will repair or replace defective products in accordance with its own best judgement. For service under this warranty, the buyer must contact Vicor to obtain a Return Material Authorization (RMA) number and shipping instructions. Products returned without prior authorization will be returned to the buyer. The buyer will pay all charges incurred in returning the product to the factory. Vicor will pay all reshipment charges if the product was defective within the terms of this warranty.

Information published by Vicor has been carefully checked and is believed to be accurate; however, no responsibility is assumed for inaccuracies. Vicor reserves the right to make changes to any products without further notice to improve reliability, function, or design. Vicor does not assume any liability arising out of the application or use of any product or circuit; neither does it convey any license under its patent rights nor the rights of others. Vicor general policy does not recommend the use of its components in life support applications wherein a failure or malfunction may directly threaten life or injury. Per Vicor Terms and Conditions of Sale, the user of Vicor components in life support applications assumes all risks of such use and indemnifies Vicor against all damages.

Vicor s comprehensive line of power solutions includes high density AC-DC and DC-DC modules and accessory components, fully configurable AC-DC and DC-DC power supplies, and complete custom power systems.

Information furnished by Vicor is believed to be accurate and reliable. However, no responsibility is assumed by Vicor for its use. Vicor components are not designed to be used in applications, such as life support systems, wherein a failure or malfunction could result in injury or death. All sales are subject to Vicor's Terms and Conditions of Sale, which are available upon request.

Specifications are subject to change without notice.

Intellectual Property Notice

Vicor and its subsidiaries own Intellectual Property (including issued U.S. and Foreign Patents and pending patent applications) relating to the products described in this data sheet. Interested parties should contact Vicor's Intellectual Property Department.

Vicor Corporation
25 Frontage Road
Andover, MA, USA 01810
Tel: 800-735-6200
Fax: 978-475-6715

email

Customer Service: custserv@vicorpower.com
Technical Support: apps@vicorpower.com