

PFC Mini™

Power Factor Corrected AC-DC Switcher



Design Guide

and

“Quick Install” Instructions



www.vicorpower.com

TABLE OF CONTENTS

Overview of Product.....	3
Part Numbering.....	4
Mechanical Considerations.....	4
PFC Mini Do's and Don'ts.....	4
Technical Description.....	5
PFC Mini Configuration Layout.....	6
Quick Install Instructions.....	8
Mechanical Drawings.....	10
Output Connectors.....	11
Interface Connections.....	12
Serial Number.....	17
Output Power Derating.....	18
Specifications.....	19
Current Share Board.....	21
Low Leakage Version.....	23
Low Output Ripple.....	23

PFC Mini™

Power Factor Corrected AC-DC Switcher

Overview

The PFC Mini is an extremely low profile, 1 RU, switching power supply that combines the advantages of power factor correction and high power density. It can provide up to 6 isolated outputs (3 slots) and each slot accommodates the following Vicor DC-DC Converters.

VI-200/VI-J00 series: 1 VI-200 or 2 VI-J00 modules

Maxi, Mini Micro series: 1 Maxi, 2 Minis (Micros cannot be used)

The use of these converters give the PFC Mini the inherent power flexibility typical of all Vicor products. Using the VSPOC configurator tool available on vicorpower.com, anybody can now configure a PFC Mini (and other Westcor power supplies) online. Accepting input voltages of 85 Vac to 264 Vac, and 100 to 380 Vdc, the PFC Mini can provide up to 1,500 Watts in a package size of 1.72" H (43,6mm) x 6" W (152,4mm) x 12.2" L (309,9mm). The PFC Mini is factory configured to meet user requirements.

Note: If you have a PFC Mini that shipped from October 2005 onwards, please see page 17 for more details.

Standard Features

- Power Factor Correction: 0.99 at 115 Vac; 0.95 at 230 Vac
- Universal Input: 85-264 Vac, 47-500 Hz, or 100-380 Vdc
- Power Output: 1,500W at 230 Vac; 800W at 115 Vac
- Up to 6 isolated outputs (3 slots)
- Fan cooled
- Rugged: Meets Mil-Std-810E, category 10, Minimum integrity test for Vibration (units shipped after 10/05)
- Full power to 45°C; half power at 65°C
- Conducted EMI:

VI-200/VI-J00 series	Maxi, Mini Micro series
FCC Class B	FCC Class A
EN 55022 Class B	EN 55022 Class A
	(certain configurations meet EN55022 Class B.)
- Harmonic Distortion complies with EN61000-3-2
- AC Power OK status signal
- Autosense (for more information, see page 8 and page 13)
- Output overcurrent protection on all outputs
- Output overvoltage protection (not applicable when using VI-J00)
- Output overtemperature limiting (not applicable when using VI-J00)
- Ride-through (holdup) time: >20 ms at 1,200W load (nominal line)
- Size: 1.72" H (43,6mm) x 6" W (152,4mm) x 12.2" L (309,9mm)
- Safety Agency Approvals: CE Marking, cTUVus, UL

Optional Features

- Extended temperature range output converters
- Current Share Board - See page 21
- RAM modules for low noise applications - See page 23
- Connector kit available (#19-130047)
- Low leakage available - see pg 23
- Office environment fan - See page 23

Part Numbering

PFC Mini	PM_{x1-x2} x₃ (x₄)-xxxx(-x₅)(-x₆)			
e.g. PM4-22-2988	x₁	# of outputs	x₂	# of VI-200/VI-J00
PM1-03B-48	x₃	# of Maxi, Mini	x₄	Optional- standard
PM3-03-2643-2				product designator
PM6-60-2888-2-QF	x₅	Optional Factory assigned	x₆	Options codes e.g.:
		Rev. to original config.		QF - Quiet Fan/Office
				Environment
				LL - Low Leakage
	xxxx	# assigned by Westcor		

Mechanical Considerations

The PFC Mini can be mounted on either of two surfaces using standard 8-32 (4 mm) size screws. Maximum allowable torque is 4.4 in. lbs., and the maximum penetration is 0.16 in. (4mm).

When selecting a mounting location and orientation, the unit should be positioned so air flow is not restricted. Maintain a 2" (5,1cm) minimum clearance at both ends of the PFC Mini, and route all cables so airflow is not obstructed. The power supply draws air in at the fan side/AC input side and exhausts air out the load side. If airflow ducting is used, avoid sharp turns that could create back pressure. The fans move approximately 20 CFM of air.

Avoid excessive bending of output power cables after they are connected to the output terminals. For high-current outputs, use cable ties to support heavy cables and minimize mechanical stress on connectors. Be careful not to short-out to neighboring outputs. The maximum torque recommended on output nuts is 10 in. lbs.

Avoid applications in which the unit is exposed to excessive shock or vibration levels. In such applications, a shock absorbing mount design is required.

PFC Mini Do's and Don'ts

- **If Sense jumpers are removed, do not leave Sense lines open (especially if unit does not have Autosense). Sense lines must be terminated to their respective outputs. Use twisted pair 20-22 AWG wire when installing Remote Sense.**
- **NEVER** disconnect the +Out and -Out load wires while the supply is operating as disconnecting **WILL** cause damage to the power supply.
- To prevent damage to supply, verify polarity of remote sense connection before turning supply on.
- Always turn the power supply off, before disconnecting input or output wires.
- Do not restrict airflow to the unit. The cooling fan draws air into the unit and forces it out at the output terminals.
- Run the output (+/-) power cables next to each other to minimize inductance.
- Do not repair or modify the power supply in any manner. Doing so will void the warranty. Contact Factory.
- Insert proper fault protection at power supply input terminals (i.e., a fuse).
- Use proper size wires to avoid overheating and excessive voltage drop.
- Output voltages over 60Vdc, whether from individual modules or series arrays, are considered as hazardous secondary outputs under UL 60950. Appropriate care must be taken in design implementation of the supply.

Technical Description

The PFC Mini consists of an off-line single phase, power-factor-corrected front end, EMI filter, cooling fan, customer interface, associated housekeeping circuits, and a selection of Vicor's DC-DC converters.

Input AC mains voltage is applied to a terminal block. The input current is passed through an EMI filter designed to meet conducted noise limit "B" specifications in FCC Part 15 and EN55022, Class B (with VI-200/VI-J00 Series modules. If Maxi, Mini Micro series modules are used, it meets FCC Class A and EN 55022 Class A. Certain configurations meet Class B).

At start-up, inrush current is limited by a PTC thermistor. The PTC is shunted out shortly after initial power-up by a DC bus voltage sense circuit driving a relay. After rectification, the input voltage is put through a boost converter that keeps the AC input current sinusoidal and synchronized with the input AC voltage (in compliance with EN61000-3-2). The boost converter delivers a regulated input to the hold-up capacitors and a high voltage backplane. The backplane supplies power to the DC-DC converters that provide the desired low voltage regulated outputs.

Voltage conversion is achieved by Vicor's family of Zero-Current-Switching (ZCS) DC-DC converters. These are forward converters in which the main switching element switches at zero current. This patented topology has a number of unique attributes: low switching losses; high frequency operation, resulting in reduced size for magnetics and capacitors; excellent line and load regulation; wide adjustment range for output; low EMI/RFI emission and high efficiencies.

At initial power-up, the PFC Mini outputs are disabled to limit the inrush current and to allow the DC bus potential to settle out to the correct operating level. A low-power flyback converter operating with PWM current-mode control converts the high voltage DC bus into regulated low voltage to power the internal housekeeping circuits and DC cooling fans.

The internal housekeeping Vcc comes up within 2 s after the application of input power. Once the high voltage bus is within operating limits, the AC Power OK signal asserts to a TTL "1," indicating the input power is OK, and enables the power outputs. An auxiliary Vcc output of 5 Vdc sourcing up to 0.3A is provided for peripheral use.

An output Enable/Disable function is provided by using an optocoupler to control Vicor's DC-DC converters. If the Enable/Disable control pin is pulled low, the optocoupler turns on and disables the output. The nominal delay associated for an output to come up when measured from release of the Enable/Disable pin is 5-10 ms. The General Shutdown function controls all outputs simultaneously and works in a similar manner.

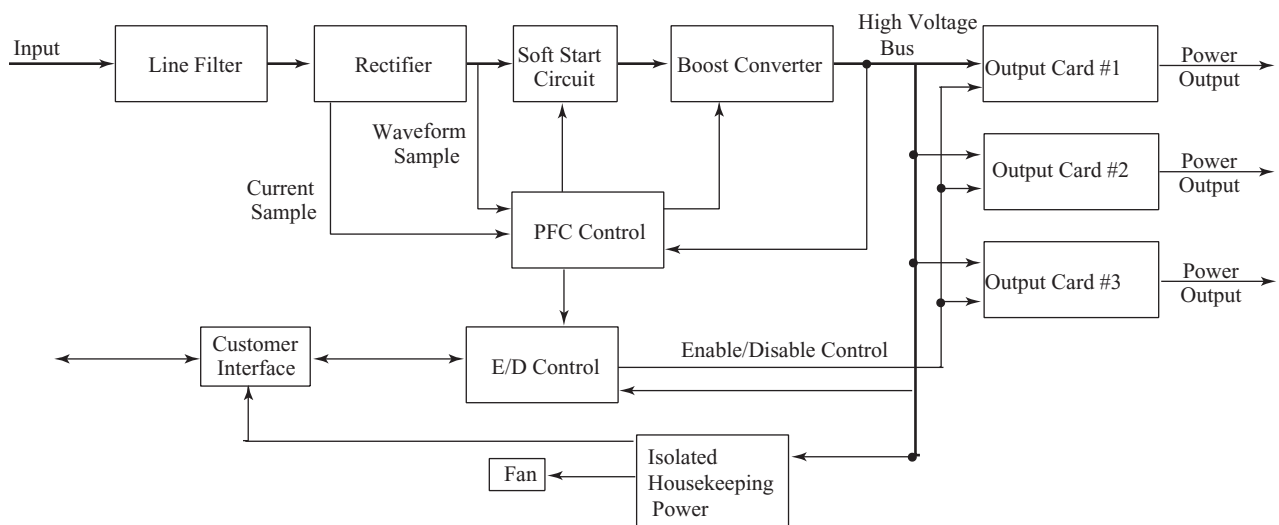

PFC Mini Configuration Layout

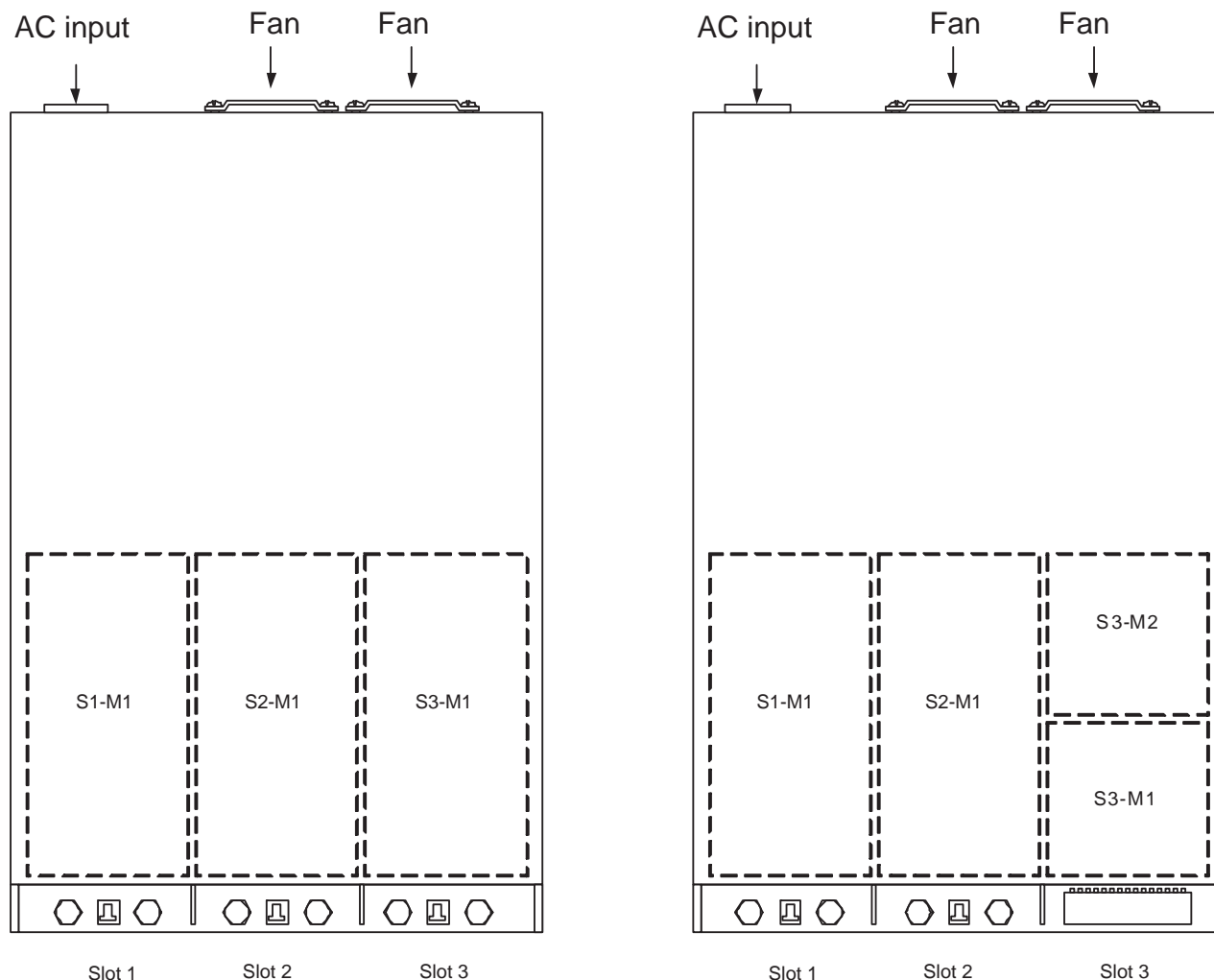

Shown above are two sample PFC Mini configuration layouts. Due to the configurability nature of the PFC Mini, various output combinations are possible. See page 11 for more information about your output connections. The PFC Mini has three slots and each slot accomodates either full or half brick modules.

Please note that the maximum output power of the PFC Mini is 1,500W @ 230Vac, 800W @ 115Vac, irrespective of the maximum output power of the modules e.g. if a PFC Mini is configured with 3 Maxi modules, on the configuration sheet, the maximum output power of the module (600W) is listed. However, irrespective of the maximum output power of the 3 Maxi modules (1,800W), the maximum output power of the PFC Mini is still 1,500W @ 230Vac and 800W @ 115Vac.

When populated with 12V modules, the maximum output power per slot is 500W (with other modules it is 600W). Hence, when a 12V Maxi module is used, the maximum output power is limited to 500W. If a 12V Mini module is used, the maximum output power is limited to 250W.

PFC Mini Configuration Layout

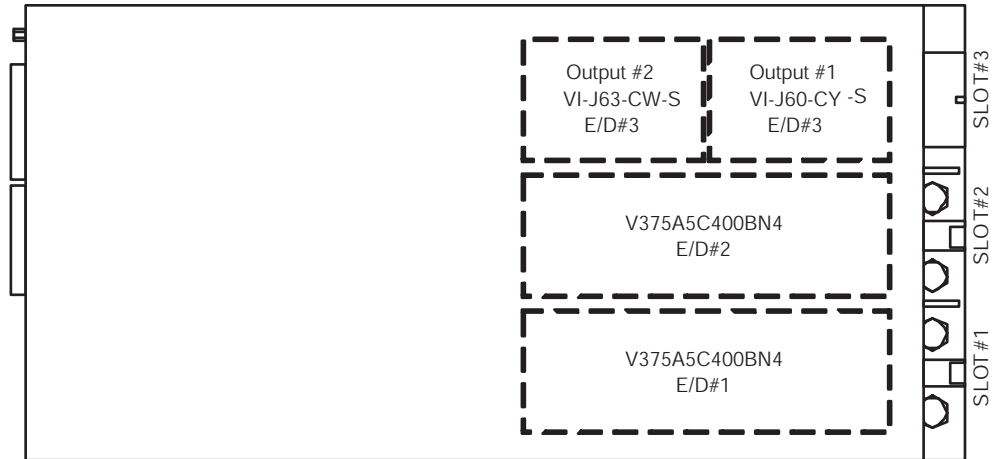

Configuration Example:

SLOT#	VOLTS	AMPS	WATTS	Modules
1	5.0	80	800	V375A5C400BN4*
2				V375A5C400BN4*
3 (M1)	5.0	10	50	VI-J60-CY-S*
3 (M2)	24.0	4.2	100	VI-J63-CW-S*

* Actual module part numbers may vary depending on customer configuration

E/D = Enable/Disable

PFC Mini “Quick Install” Instructions (See pg 10 for mechanical drawings)

Mounting the PFC Mini

- * Mount the PFC Mini on either of two sides.
- * Use #8-32 or 4mm mounting screws. Maximum penetration should not exceed 0.16" (4mm).
- * Maintain 2" (5,1cm) clearance at both ends of power supply for airflow.

Input Connections

Input Power MBJ1

- * Apply input AC power to terminal block MBJ1 using a pressure screw terminal.
- * Strip length of AC power conductors to be .35 inches.
- * Maximum torque is 4.4 lb-in.
- * **Place a fuse or circuit breaker in the input line for safety requirements.**
- * The connector manufacturer recommends the wires not be tinned. A ferule can be used to prevent fraying.

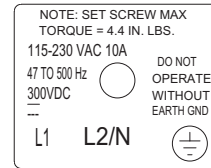

INPUT CONNECTIONS
 MBJ1-1 EARTH GROUND
 MSJ1-2 L2-NEUTRAL
 MBJ1-3 L1

Output Connections (See page 11 for more details on output connectors)

Power Connections

Installing bus bars on output studs (when full size module used):

- * The right stud is Positive and the left stud is the Return
- * Remove the top nut and place ring lug over output stud.
- * Do not remove the lower nut next to the PCB.
- * Replace and tighten the nut to a torque of **10 inch pounds. Do Not Over-Tighten Nuts.**

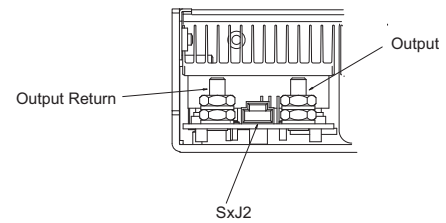

Installing power connectors with 18 pin molex connectors⁺ (when half size module used):

- * SxJ1-1¹, SxJ1-10, SxJ1-11 are Positive for output #1, while pins SxJ1-2, SxJ1-3, SxJ1-12 are the Return. SxJ1-7, S3J1-8 and SxJ1-16 are Positive for output #2, while pins SxJ1-9, SxJ1-17 and SxJ1-18 are the Return.
- * Use Molex mating receptacle #39-01-2180 with #44476-3112 terminals.
- * Attach 18-24 AWG stranded wire using Molex tool #11-01-0199.
- * Current PFC Minis have 18 Pin SxJ1 connectors.

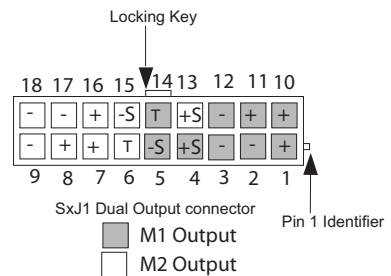

⁺ Outputs with current molex connectors are limited to 9A/pin (27A per output)

¹Where x refers to the slot number.

Note: Effective January 2001, all PFC Mini units have 18 pin connectors (Molex PN#39-01-2180) versus the 14 pin (Molex PN# 39-01-2140). If you already have a 14 pin design in, remove the harness assembly from the 14 pin connector housing and insert the harness connector pins into the 18 pin connector housing. For further information, contact an Applications Engineer.

Sense Connections

Note: PFC Mini units built after 12/2000 have been equipped with a feature called **Autosense**. If no sense connections are made, the PFC Mini will automatically operate in Local Sense mode. If remote sense connections are made, the PFC Mini will operate in a Remote Sense mode.

For units built before 12/2000 (units without Autosense), sense connections must **ALWAYS** be made. Not connecting Sense Lines to their respective outputs can cause failure to the unit.

Sense Connections on output connections with studs

- * PFC Minis are currently shipped with Autosense installed. Those without the Autosense were shipped with Local Sense installed. (See note on page 8)
- * If Remote Sense is desired, remove jumpers MBJ1 and J3, located behind the sense connector.
- * Connector pin SxJ2-2 is the +Sense and SxJ2-3 is the -Sense.
- * Use Molex mating receptacle #50-57-9403 with #16-02-0103 terminals.
- * Attach terminals to 20-22 AWG stranded twisted pair wire using Molex tool # 11-01-0208.
- * Attach opposite end of sense lines to point where regulation is desired.
- * **Verify that sense lines are not cross-connected.**

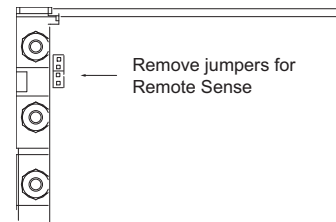

Sense Connections on output connection with molex connectors

- * PFC Minis are currently shipped with Autosense installed. Those without the Autosense were shipped with Local Sense installed. (See note on page 8)
- * If Remote Sense is desired, remove jumpers on MBJ1 and J3, located on either side of the output connector.
- * Connector pin SxJ1-4 is the +Sense and SxJ1-5 is the -Sense for output #1. SxJ1-13 is the +Sense and SxJ1-15 is the -Sense for output #2.
- * Use Molex mating receptacle #39-01-2180 with #39-00-0039 terminals.
- * Attach 18-24 AWG stranded twisted pair wire using Molex tool #11-01-0197.

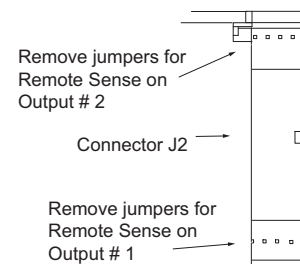

Trim Connections

Trim Connections on outputs with studs:

- * SxJ2-1 provides Trim access.
- * Use Molex mating receptacle #50-57-9403 with #16-02-0103 terminals.
- * Attach 20-22 AWG stranded wire using Molex tool #11-01-0208.

Trim Connections on outputs with molex connectors:

- * SxJ1-14 provides Trim access for output #1, and SxJ1-6 provides Trim access for output #2.
- * Use Molex mating receptacle #39-01-21 with #39-00-0039 terminals.
- * Attach 18-24 AWG stranded wire using Molex tool #11-01-0197.

Trim Connector

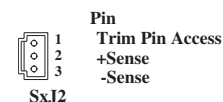

Locking Key

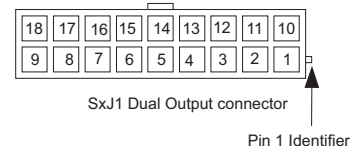

Interface Connections

- * J3-1 to 3 are Enable/Disable for cards 1-3, respectively.
- * J3-4 is Signal Ground, J3-5 is +5V, J3-6 is AC Power OK, and J3-7 is General Shutdown.
- * Use mating receptable AMP P/N 205204-4 with terminals AMP P/N 66506-9.
- * Attach terminals to 18-24 AWG stranded wire.

J3 INTERFACE CONNECTION

MATING HDWR:
HOUSING: AMP P/N 205204-4
TERMINALS: AMP P/N 66506-9
SCREW LOCK: AMP P/N 205980-4
CRIMP TOOL: AMP 58448-3

J3 INTERFACE PIN OUT

J3-1	E/D-1
J3-2	E/D-2
J3-3	E/D-3
J3-4	SIGNAL GROUND
J3-5	VCC +5V 300mA
J3-6	ACOK AC POWER OK
J3-7	GSD GENERAL SHUTDOWN
J3-8	SPARE
J3-9	SPARE

PFC Mini Mechanical Drawings

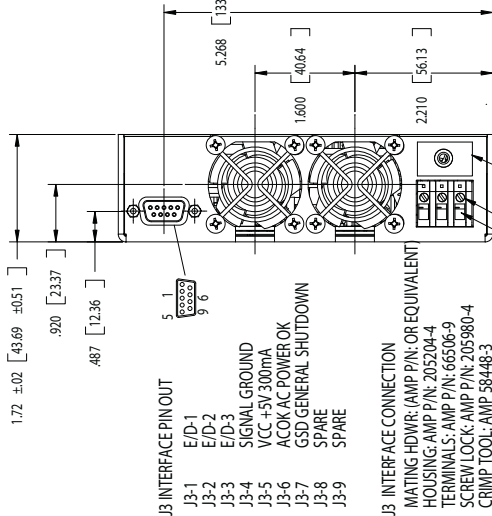
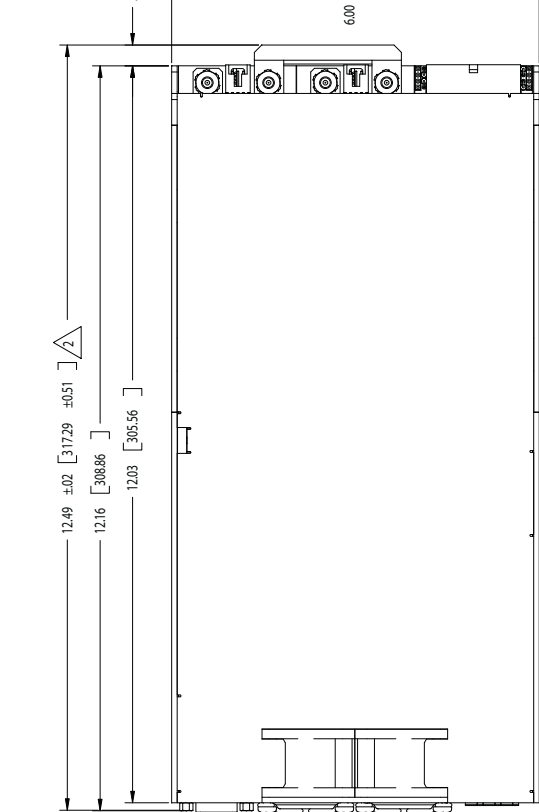
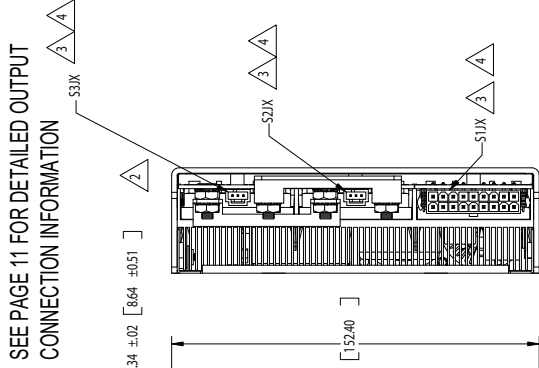

J3 INTERFACE PIN OUT
 J3-1 E/D-1
 J3-2 E/D-2
 J3-3 E/D-3
 J3-4 SIGNAL GROUND
 J3-5 VCC +5V 300mA
 J3-6 ACOK AC POWER OK
 J3-7 GSD GENERAL SHUTDOWN
 J3-8 SPARE
 J3-9 SPARE

J3 INTERFACE CONNECTION
 MATING HDWR: (AMP P/N: OR EQUIVALENT)
 HOUSING: AMP P/N: 205204-4
 TERMINALS: AMP P/N: 66506-9
 SCREW LOCK: AMP P/N: 205980-4
 CRIMP TOOL: AMP 58448-3

14 AWG WIRE
 CLAMPING SCREWS

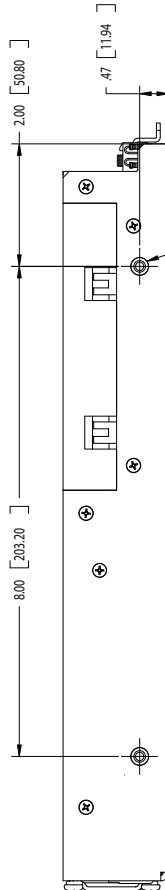

CUSTOMER MOUNTING HOLES:
 2X #4-32 X .156 OR M4 X .4mm MAX L.G.
 FROM OUTSIDE OF POWER SUPPLY



NOTE: FOR INCREASED OUTPUT POWER,
 CURRENT SHARE BOARDS ARE AVAILABLE.
 WITH VI-200/VI-100 MODULES CSB-01
 WITH MAXIMINI MODULES CSB-02

SEE PAGE 21 AND 22 FOR MORE INFORMATION ON
 CURRENT SHARE BOARDS.

NOTES: UNLESS OTHERWISE SPECIFIED

1. INTERPRET DRAWING PER ANSI Y14.5-1994.

2 WITH OPTIONAL BUSBAR.

A COMPLETE SET OF MATING CONNECTORS CAN
 BE PURCHASED FROM WESTCOR BY SPECIFYING
 CONNECTOR KIT P/N: 19-130047

REF DESIGNATION LEGEND

MB = MOTHER BOARD

S1 = (SLOT 1) DAUGHTERBOARD MODULES E/D 1.

S2 = (SLOT 2) DAUGHTERBOARD MODULES E/D 2.

S3 = (SLOT 3) DAUGHTERBOARD MODULES E/D 3.

All Westcor power supplies can now be configured online
 using VSPOC, the online configurator tool available on vicorpower.com

BOTTOM VIEW
 SCALE: 1:2

Output Connectors for PFC Mini

A. OUTPUT STUDS - SINGLE OUTPUT (when populated with Full Size modules)

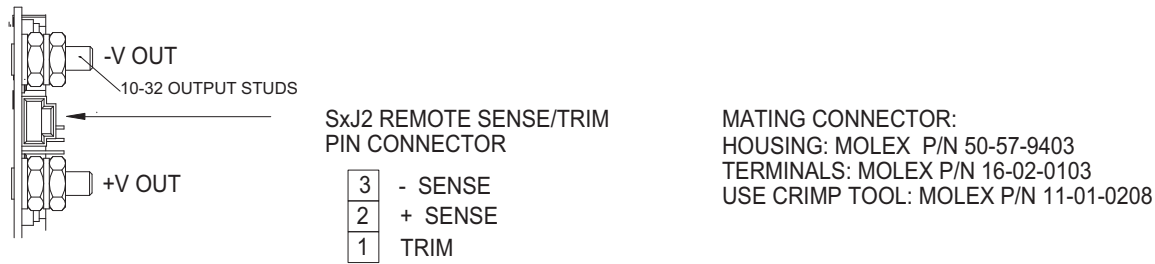

B. MOLEX CONNECTOR - SINGLE OR DUAL OUTPUT - (when populated with Half Size modules) 18 Pin Housing

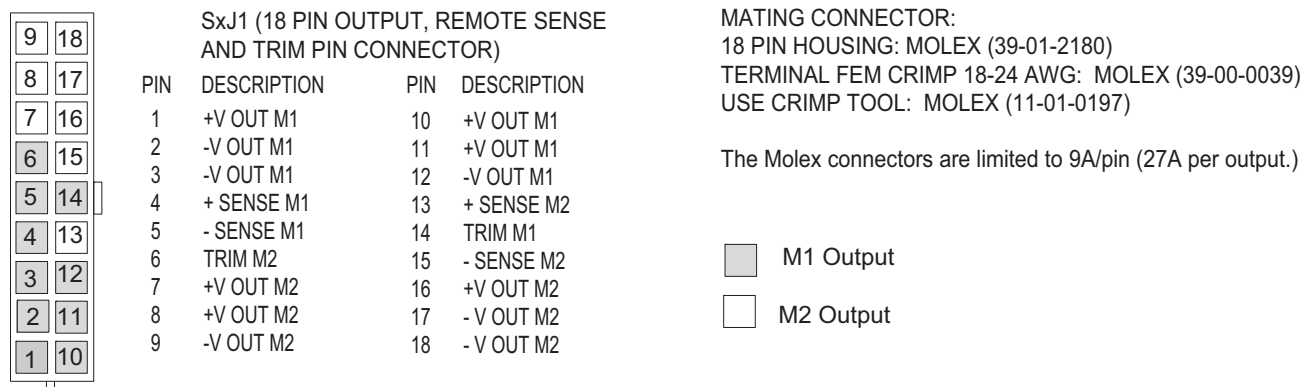

C. MOLEX CONNECTOR - SINGLE OR DUAL OUTPUT SLOT (14 Pin Housing - PFC Minis built prior to 1/2001)

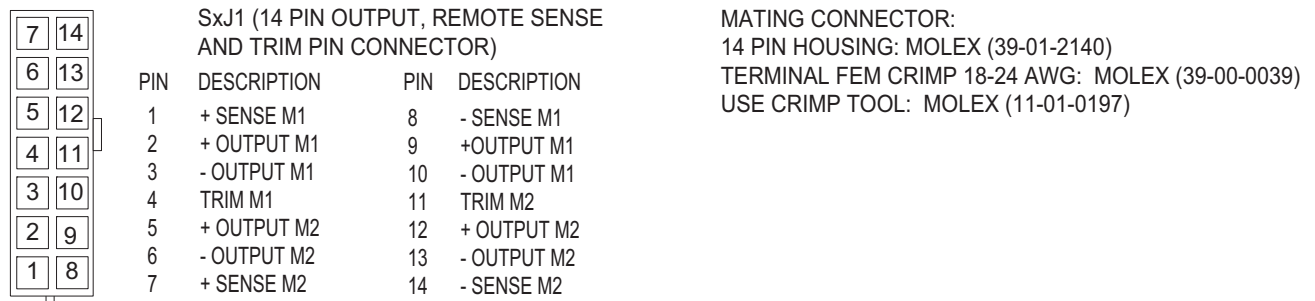

OPTIONAL CONNECTOR KIT FOR PFC MINI (PART # 19-130047. Available for purchase from Westcor)

ITEM	QTY	DESCRIPTION	VENDOR # 1	PART NO.
1	3	HOUSING 3 POS .100 CTR W/LATCH	MOLEX	50-57-9403
2	10	TERM FEM CRIMP 22-24AWG SEL GOLD	MOLEX	16-02-0103
**		CRIMP TOOL FOR ITEM 2	MOLEX	11-01-0208
3	1	HOUSING FEMALE D-SUB 09 PIN	AMP	205204-4
3	10	TERM MALE CRIMP 22-24 AWG TIN	AMP	66506-9
3	1	SCREW LOCK MALE (1 PAIR)	AMP	205980-4
**		CRIMP TOOL FOR ITEMS 3	AMP	58448-3
4	3	HOUSING 18 POS .165 CTR W/LATCH	MOLEX	39-01-2180
5	60	TERM FEM CRIMP 18-24 AWG SEL GOLD	MOLEX	39-00-0039
**		CRIMP TOOL FOR ITEM 5	MOLEX	11-01-0197
6	60	TERM FEM CRIMP 16 AWG SEL GOLD	MOLEX	45750-3211
**		CRIMP TOOL FOR ITEM 6	MOLEX	11-01-0199

** ITEMS FOR REF ONLY (NOT INCLUDED IN KIT)

Interface Connections

Chassis Input Power Terminals (MBJ1)

Input AC power is applied to terminal block MBJ1 using a pressure screw terminal that accepts a maximum wire size of 14 AWG. The insulation should be stripped 0.35 inches and the maximum torque applied to the screws should not exceed 4.4 lb-in. The connector manufacturer recommends the wires not be tinned. A ferrule (Phoenix P/N 32-00-58-0, provided in optional connector kit) can be used to prevent fraying. MBJ1-1 (GND) is Earth Ground for safety; MBJ1-2 (L2) and MBJ1-3 (L1) are the other "hot" connections.

A fault clearing device, such as a fuse or circuit breaker, with a maximum 15A rating at the power supply input is required for safety agency compliance. It should be sized to handle the start-up inrush current of 8.5A pk at 115 Vac and 17A pk at 230 Vac.

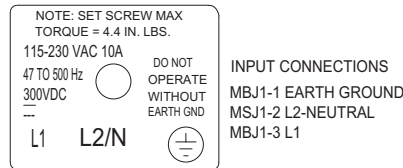

Figure 2. Input Power Terminal MBJ1

Output Power Connections

There are two types of output power terminals available in the PFC Mini. Outputs from full-sized converters are terminated in two 10-32 plated steel bolts. The positive polarity of the output is the right bolt when viewed from the output end. Outputs from half-sized converters terminate in a Molex connector. Note: The Molex connectors are limited to 9A/pin (27A/output). Each power output is isolated, so outputs of positive or negative polarity can be configured through proper selection of the output reference terminal.

In order to minimize parasitic cable inductance and reduce EMI, the output power cables should be routed in close proximity to one another, and large current loops should be avoided. To avoid excessive voltage drop, do not undersize power cables, especially for high current outputs. Excessive cable inductance coupled with large capacitive loading can introduce instability in switching power supplies. This problem can be avoided with proper system design. Consult Vicor's Applications Engineering Department for assistance with applications that use long cable lengths and excessive load capacitance.

Note: Effective January 2001, PFC Minis using VI-J00 modules on a dualboard (dual output) now require an 18 pin connector (Molex PN# 39-01-2180) versus a 14 pin (Molex PN# 39-01-2140), making them the same as dualboards with Mini converters. If you already have a 14 pin design in, the change to the 18 pin should not affect your design in. Remove the harness assembly from the 14 pin connector housing and insert the harness connector pins into the 18 pin connector housing. Contact Field Applications for further information.

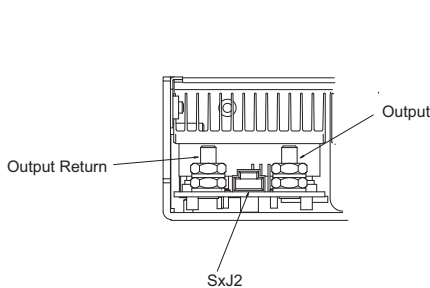

Figure 3. Power Connections for Single Output

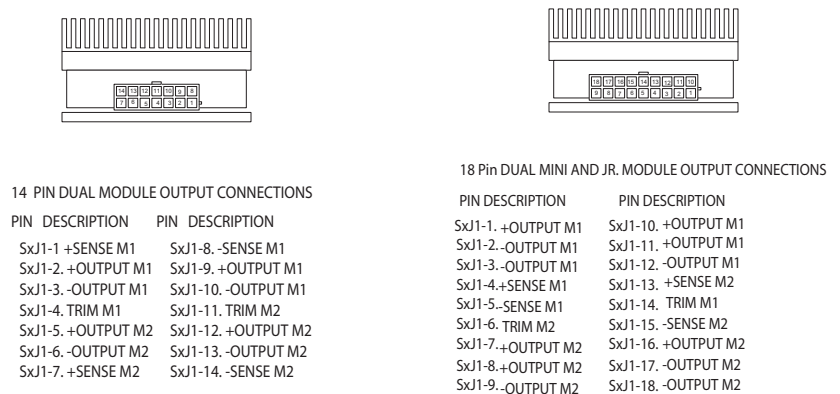

Figure 4. Power connections for Dual Output

+Sense/-Sense (SxJ2/SxJ1)

Current PFC Mini units are shipped with Autosense installed. If the unit does not have Autosense, sense selection is very important. In units without Autosense, the Sense lines for the outputs are shipped from the factory with Local Sense installed. If Remote Sense is desired the Local Sense jumpers can be removed for individual outputs. If the Local Sense jumpers are removed, the Sense lines must be connected for Remote Sense. **Leaving the Sense lines open will prevent proper output regulation and can result in damage to the unit.**

When Local Sense is used, the power supply will regulate the output at the output terminals. The voltage appearing at the load may drop slightly due to voltage drop in the power cables. If it is necessary to compensate for voltage drop along the output power cables, the output can be trimmed up or configured for Remote Sense. Use stranded twisted pair 20-22 AWG wire for the Remote Sense lines. Remote Sense can compensate for a voltage drop of up to 0.5V, or 0.25V on each leg.

Installing Remote Sense requires the Local Sense jumpers to be removed. On single output cards, the Local Sense jumpers are located behind the Sense connector on MBJ1 and J3. To remove the jumpers, make certain the power to the supply is off, and pull them off the connectors MBJ1 and J3. On dual output cards, the local Sense jumpers are on either side of the output connector at MBJ1 and J3. The jumpers at MBJ1 are for output #1, and the jumpers at J3 are for output #2.

The Sense connector for a single output board is a 3 pin connector providing the +Sense connection on SxJ2-2 and the -Sense connection on SxJ2-3. The Sense connector for a dual output board is a 18 pin connector that also provides the output and trim connections. +Sense and -Sense for the first output are located on SxJ1-4 and SxJ1-5, respectively. +Sense and -Sense for the second output are located on SxJ1-13 and SxJ1-15, respectively.

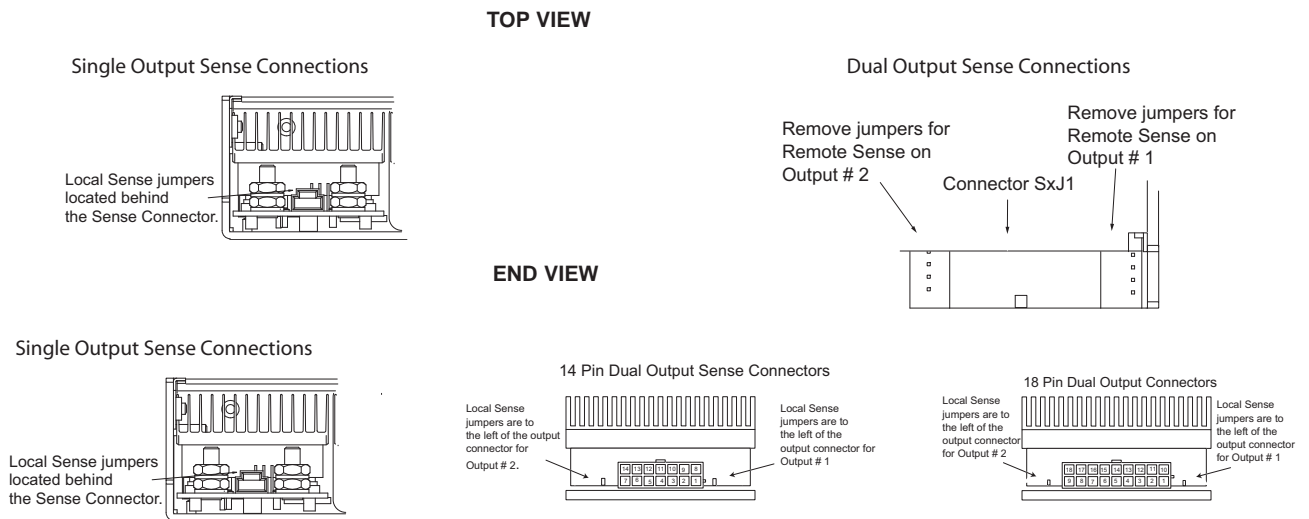

Figure 5. Removing Local Sense Jumpers

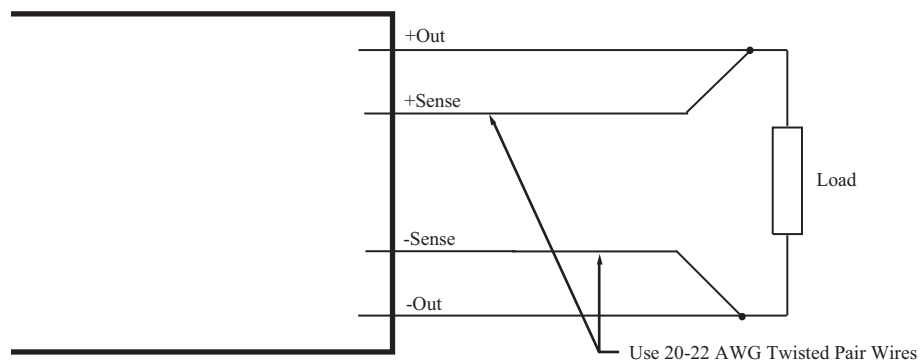

Figure 6. Remote Sense

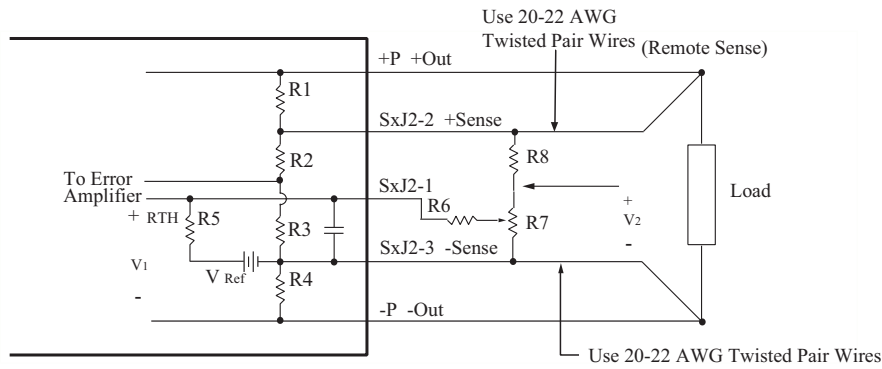

Figure 7. External Trim

OUTPUT MODULE	V _{ref}	R _{TH}
VI-200/VI-J00 ≥3.3V	2.5V	10kΩ
VI-200/VI-J00 <3.3V	0.97V	3.88kΩ
Maxi, Mini Micro series (Predefined)	1.23V	1kΩ
Maxi, Mini Micro series (User Defined)	1.23V	Consult Factory

Table 1. Module Internal Reference Voltages and Thevenin Resistances.

External Trim (SxJ2/SxJ1)

The Trim pin at SxJ2 is referenced to the -Sense pin and can be used for external control of the output voltage. For dual output cards, the Trim pins are available at SxJ1-14 and SxJ1-6 for outputs 1 and 2, respectively. A 10% increase to the trim pin voltage will result in a 10% increase in output voltage. Reducing the trim pin voltage by 10% will result in a 10% decrease in output voltage.

Note: Converters are sometimes pretrimmed at the factory if a nonstandard output voltage is requested. If a nonstandard voltage is requested, the resistor calculations will differ from those below. Consult the factory for assistance.

Example:

±10% trim adjust on a 12V nominal output.

Figure 7 shows a typical variable trim circuit. Using a 10k trimpot (R7), the resistor values for R6 and R8 can be calculated as follows:

$$V_1 = V_{ref} + 10\% = 2.75V \quad \text{Given: } V_{ref} = 2.5V \text{ (see Table 1)}$$

$$I_{R5} = (2.75V - V_{ref})/R_{TH} = (2.75V - 2.5V)/10k\Omega = 25\mu A \quad \text{Given: } R_{TH} = 10k\Omega \text{ (see Table 1)}$$

Setting the bottom limit:

$$V_{R6} = 2.5V - 10\% = 2.25V$$

And since $I_{R5} = I_{R6} = 25\mu A$,

$$R6 = V_{R6}/I_{R6} = 2.25V/25\mu A = \underline{90k\Omega}$$

$$V_2 = V_1 + V_{R6} = 2.75V + 2.25V = 5V$$

$$I_{R7} = V_2/R7 = 5V/10k\Omega = 500\mu A$$

$$I_{R8} = I_{R7} + I_{R6} = 525\mu A$$

$$V_{R8} = (V_{nom} + 10\%) - V_2 = 13.2V - 5V = 8.2V \quad \text{Given: } V_{nom} = 12V$$

$$R8 = V_{R8}/I_{R8} = 8.2V/525\mu A = \underline{15.62k\Omega}$$

Consult Applications Engineering when trimming outputs below 5V.

Signal Ground (J3-4)

Signal Ground on J3-4 is an isolated secondary ground reference for all J3 interfacing signals. This is **not** the same as Earth Ground on input power connector MBJ1.

Enable/Disable (J3-1 to J3-3)

The Enable/Disable control pins allow outputs to be sequenced either on or off. J3-1 through J3-3 are the control pins for output cards 1 through 3, respectively. For 2-output cards, both outputs are enabled or disabled with a single control. The Enable/Disable pins should be pulled low to less than 0.7V with respect to Signal Ground to disable the outputs. They will source 4mA maximum. These pins should be open circuited or allowed to exceed 4.5V when enabled. Do not apply more than 5V to these inputs.

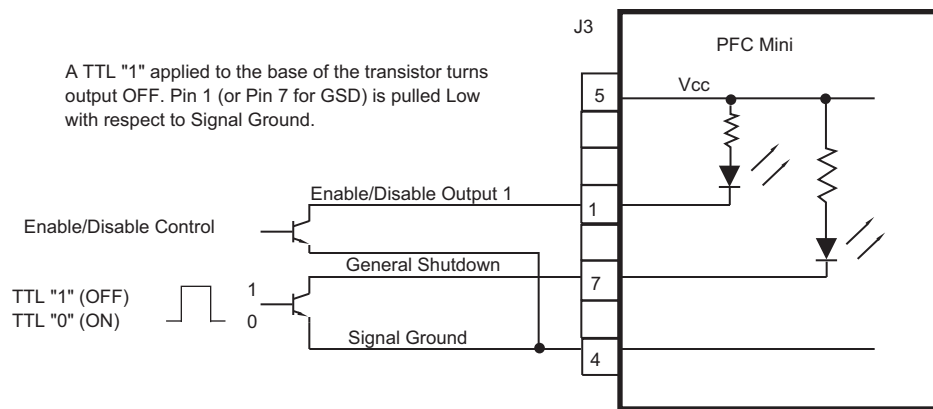

Figure 8. Enable/Disable and General Shutdown

Enable/Disable control of Maxi, Mini Micro series Module Arrays

When using the Enable/Disable function on an output that consists of two or more Maxi/Mini series modules, it is necessary to connect the E/D pins of the corresponding module locations together such that both modules are commanded to turn ON or OFF simultaneously.

Example: S1 and S2 has been configured as a single output parallel array (see Fig. 9)

In order to disable the 48V output, E/D 1 and E/D 2 should be shorted together as shown in Fig.9. With E/D 1 and 2 connected together, a single switch can then be used to remotely enable and disable the output.

****Note:** For single output Maxi/Mini series power supply configurations, the simplest method of remotely enabling and disabling the output is to use the General Shutdown (GSD) function.

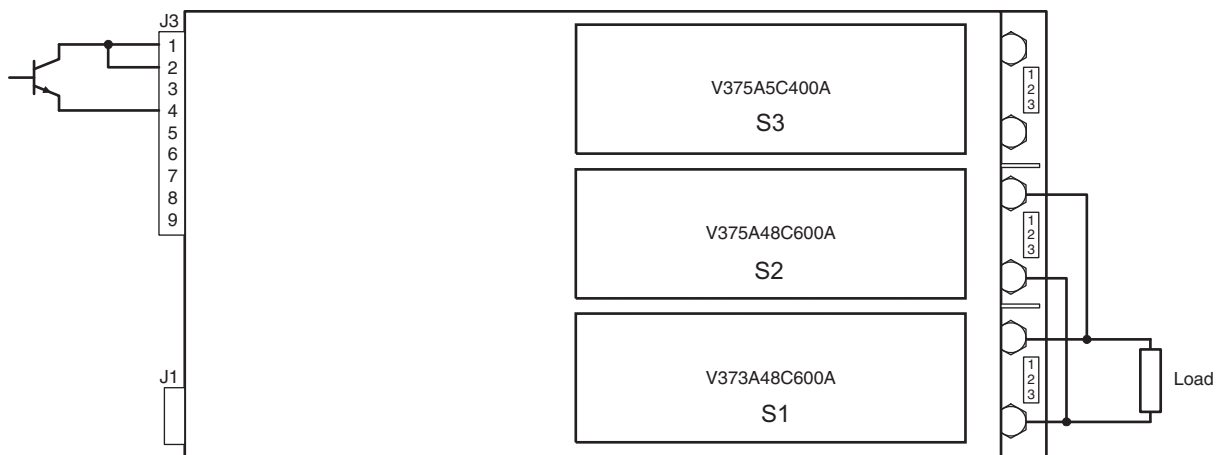

Figure 9. Enable/Disable Control of Maxi, Mini Micro series Module Arrays

General Shutdown /GSD (J3-7)

The GSD control pin on J3-7 allows simultaneous shutdown of all outputs. This pin must be pulled down to less than 0.7V, and will source 4mA maximum to shut down all outputs. The GSD pin should be open circuited or allowed to exceed 4.5V when not in use, or when the outputs are to be enabled. Do not apply more than 5V to this input at any time. Normal open circuit voltage is 1.5 to 3V with respect to Signal Ground.

AC OK (J3-6)

AC OK is an active high TTL compatible signal and provides a status indication of the AC input power. It is on pin J3-6 and is capable of sinking 16 mA maximum. This signal switches to a TTL "1" when the high voltage bus exceeds low-line condition during turn-on. Upon loss of input power, the bus voltage will drop, causing the AC OK signal to go low. A minimum of 3 ms holdup time is provided for a 1,200W load following the loss of the AC OK signal.

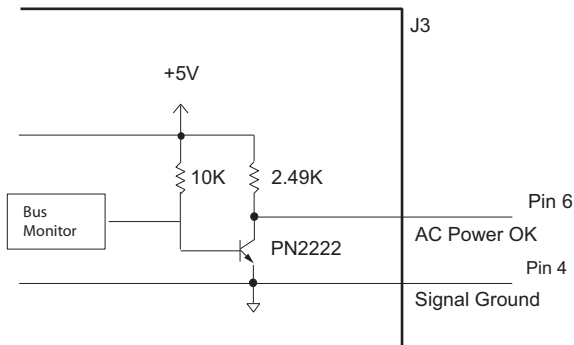

Figure 10. AC OK

Auxiliary Vcc +5V/0.3A (J3-5)

The Vcc on J3-5 is an auxiliary 5V regulated power source. It is +5 Vdc +/-5% with respect to Signal Ground and can supply 300 mA maximum. It is short-circuit-proof, but if shorted, all outputs will shut down through the Enable/Disable circuitry.

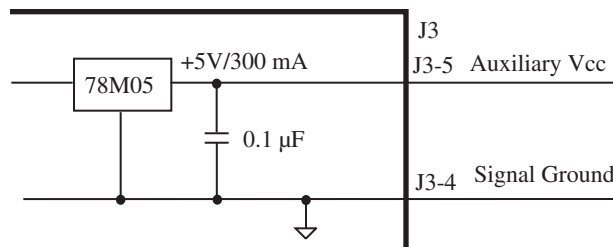

Figure 11. Auxiliary Vcc

Single Output Power Supplies (Arrays)

Westcor's standard configuration for single output power supplies is to set the left module (as seen from looking at the power supply output) as the controlling module of the array.

Minor changes for PFC Mini shipped October 2005 onwards

As part of our philosophy of continuous improvement, for the PFC Mini, Westcor made a number of changes to the unit. Usually such actions have no impact on form, fit, or function of the supplies. In this instance, the improvements required minor changes in the external appearance of the supply. The fans have been moved 0.62" and are now centered. The D-Sub logic connector has also been rotated 90 degrees. Please see the following photos for a visual comparison. **No other external dimensions, mounting locations, or performance characteristics have been changed.**



PFC Mini - without change



PFC Mini - with change

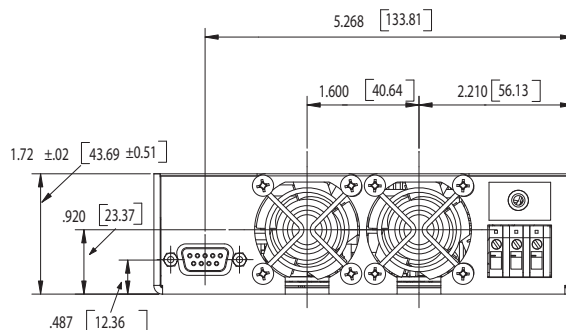

How to identify when your unit was manufactured

Serial numbers for Westcor products are determined as follows:

XXXXXXXXMMYY

XXXXXXXX= Factory assigned

MM = Month of manufacture

Y = Last digit of year of manufacture

PFC Mini Output Power vs. Input Voltage

PFC Mini
Output Power vs. AC Input Voltage

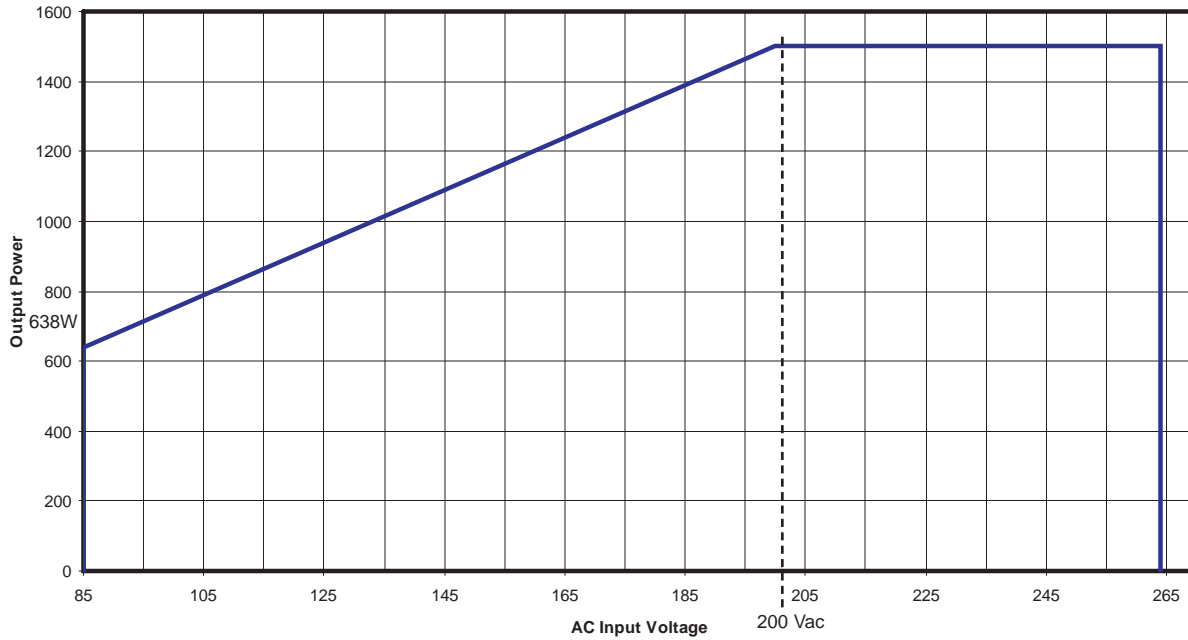

PFC Mini
Output Power vs. DC Input Voltage

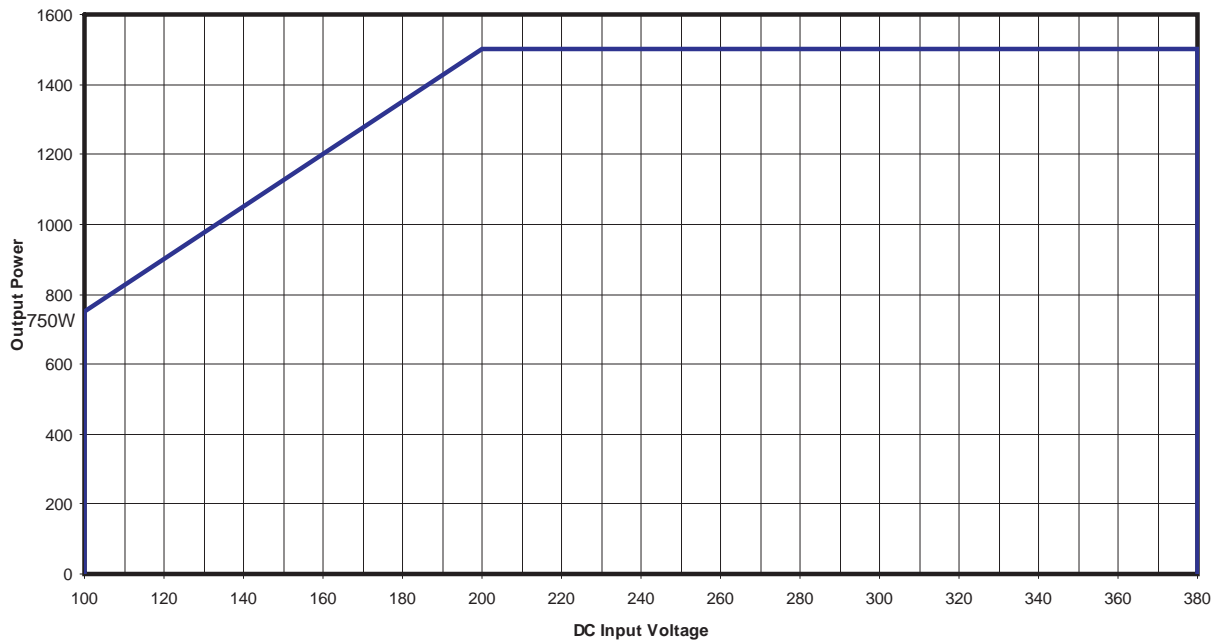

Specifications (Typical at 25°C, nominal line and 75% load, unless otherwise specified)**GENERAL**

Number of Outputs	1-6
Efficiency	> 80%
Safety Approvals	cURus – UL 60950-1, CSA 60950-1; cTUVus – EN 60950-1, UL 60950-1, CSA 60950-1 CE Mark – Low Voltage Directive, 73/23/EEC amended by 93/68/EEC
Vibration (units shipped after 10/2005)	Meets Mil-Std-810E, Category 10, Minimum Integrity test
Maximum Output Power+ (+Not to exceed an <u>input</u> current of 10A)	800W@ 115 Vac; 1,500W@ 230 Vac

Note: Only PFC Minis populated with 12V Maxi modules are limited to 500W max. per slot. With 12V Mini modules, it is limited to 250W.

INPUT

Input	85-264 Vac, 47-500Hz; 100-380 Vdc
Line/Load Regulation	VI-200/VI-J00:± 0.2% max.10% to full load; ± 0.5% max. 0 to 10% load
Line Regulation	Maxi/Mini:± 0.20% max. to 0.3% max LL to HL, Full Load
Inrush Current	8.5A pk @ 115 Vac; 17A pk @ 230 Vac
Ride Through Time	20 ms at 1,200W load
Conducted EMI	<u>VI-200/VI-J00 Ss:</u> <u>Maxi, Mini</u> (some configs. may meet Class B) EN 55022 Class B EN 55022 Class A
Power Factor	0.99@ 115Vac: 0.95 @230Vac
Voltage Fluctuations and Flicker	EN61000-3-3
ESD Susceptibility	EN61000-4-2, level 3, Performance Criteria A
RF Radiated Immunity, 10v/m	EN61000-4-3, Performance Criteria A
Transient Burst Immunity	EN 61000-4-4, Level 3, Performance Criteria B
Surge Immunity	EN 61000-4-5 Installation Class 3, Performance Criteria B
RF Conducted Immunity	EN61000-4-6, limit Class 3 Performance Criteria A
Voltage Dips and Interrupts	EN61000-4-11
Dielectric Withstand	Primary to Chassis GND = 2,121 Vdc Primary to Secondary = 4,242 Vdc Secondary to Chassis GND = 750 Vdc

* See Vicor module specifications. A preload may be necessary for modules trimmed down below 90% of normal output voltage.

OUTPUT**VI-200/VI-J00 Modules**

Parameter	MIN.	TYP.	MAX.	UNITS	NOTES
Setpoint Accuracy*		0.5	1	%	of Vnom
Load/line Regulation			± 0.2	%	10% to full load
Load/line Regulation			± 0.5	%	No load to 10% load
Temperature Regulation		0.01	0.02	%/°C	Over rated temp.
Long Term Drift		0.02		%/K hours	
Output Ripple & Noise:					
≤ 10V out		100		mV	20 MHz bandwidth
> 10 V out		1.0		% Vout	20 MHz bandwidth
Voltage Trim Range					
VI-200/VI-J00 series Slots		50-110		% V out	± 10% on 10-15 Vout
Total Remote Sense Compensation	0.5			Volts	Autosense. See pg.6 & 11
OVP Set Point¹	115	125	135	%Vout	Recycle Power
Current Limit	105	115	125	% of I max	Auto Recovery
Short Circuit Current	20 (105 ²)		130	%	
Overtemperature Limiting					Not available on VI-J00

* For special and adjustable voltages, maximum setpoint accuracy is 2% of Vnom.

¹ 131% Nominal for Booster Modules. No OVP for VI-J00

² VI-J00 modules only.

OUTPUT (CONT'D.)**Maxi, Mini Micro series Modules (Maxi and Mini modules only)**

Parameter	MIN.	TYP.	MAX.	UNITS	NOTES
Setpoint Accuracy*		±0.5	±1	% of V _{NOM}	
Load Regulation		±0.1		% of V _{NOM}	See module design guide for exact specifications.
Temperature Regulation		0.002	0.005	%/°C	-20 to 100°C
Long Term Drift		0.02		%/K hours	
Output Ripple and noise:					
≤ 10V out		100		mV	20 MHz bandwidth
> 10 V out		1.0		% V _{out}	20 MHz bandwidth
Voltage Trim Range					
Maxi/Mini Slots		10-110		% V _{out}	Preload may be required.
Total Remote Sense Compensation	0.5			Volts	Autosense. See pg.6 & 11
OVP Set Point	112		135	% of V _{out}	Recycle power
Current Limit		115	135	% of I max	Auto Recovery
Overtemperature Limiting	100	115			MMM OTL is non-latching

* For special, adjustable voltages and 48Vdc outputs, maximum setpoint accuracy is 2% of Vnom.

Note: See individual module datasheets for specific module specifications.

ENVIRONMENTAL

Storage Temperature	-40°C to +85°C
Operating Temperature	
Full Power	-20 to +45°C*
Half Power	-20 to +65°C

* 45°C is the maximum operating temperature. If one is using a Maxi/Mini module less than 24V output and more than 500 Watts, the maximum operating temperature is 40°C.

Specific temperature data on all module configurations can be obtained by contacting Applications Engineering.

Altitude	Derate 2.6% total output power for each 1,000 ft to a maximum operating altitude of 15,000 ft. Non-operating storage maximum altitude is 40K. 75% maximum load
Humidity	0 to 95% non condensing
Product Weight	5.5 lbs. (2,5 kg)
Dimensions	1.72" H (43,6mm) x 6.0" W (152,4mm) x 12.2" L (309,9mm)
Warranty*	2 years limited warranty. See vicorpower.com for complete warranty statement.

* Opening, repairing or modifying the unit will void the warranty. If you have any problem with the power supply, please contact Customer Service at 1-800-735-6200. If the unit needs to be returned for inspection/analysis, an RMA number will be issued. All units must have a RMA number prior to return.

CURRENT SHARE BOARD - Optional Feature

"Current sharing" also known as Load Sharing, is the ability to divide the output current evenly across all active power supplies. This greatly reduces stresses on each power supply and allows them to run cooler, resulting in higher reliability. Standard "current sharing" techniques typically utilize shunt resistors or Hall Effect devices to measure the current from each power supply. Power shunt resistors continually dissipate power and require cooling especially when dealing with high output currents of >100Amps. Hall Effect devices measure magnetic fields generated by current flowing through a conductor and, although they dissipate no power, they tend to be large and expensive.

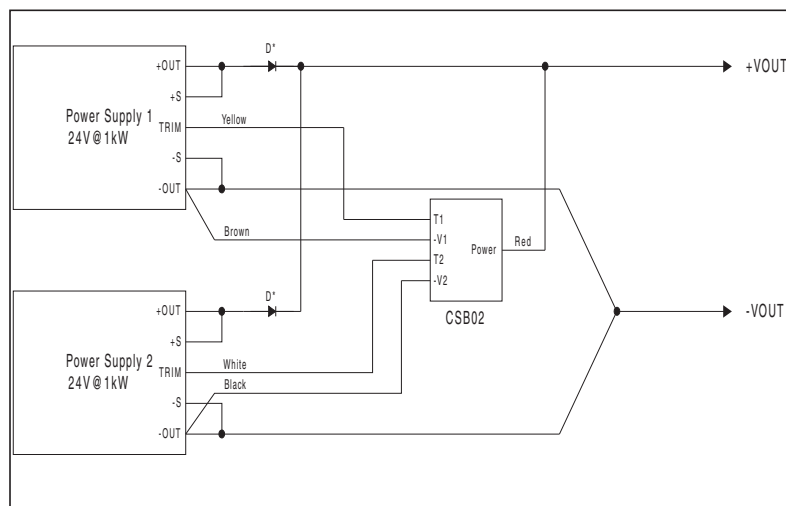

Figure 1. CSB Interconnect Example

First developed by Westcor Engineering for paralleling MegaPAC supplies, the Box-to-Box Current Share Board or CSB allows two or more Vicor power supplies to current share by utilizing the inherent voltage drop produced in the negative output return cable. This eliminates the need for additional shunt resistors or expensive Hall Effect devices and provides a simple 5 wire connection method to achieve a $\pm 1\text{mV}$ accuracy between the Negative Output power rails. This accuracy translates to a 1% current sharing if there is a total of 100mV conductional voltage drop in the negative return path.

Constructed as a current source to drive the Trim pin of a Vicor module, the design uses an accurate comparator circuit to monitor the power returns. In addition, the circuit is unidirectional and can only trim an output voltage up. The benefit is that only the supply that is supporting less current is adjusted up. This action balances the currents to the load by matching the output voltages of the supplies. In the case of one supply failing, the circuit will attempt to trim the failed supply only. This will leave the remaining functional supply alone to provide power to the load at its nominal voltage. Thus the circuit also offers simple redundancy. In addition, because CSB functions as a current source, the Trim outputs (T1 and T2) of the CSB can be placed in parallel to create a summing node. This allows current sharing between more than two supplies by paralleling the T2 output of one CSB circuit with the T1 output of the next CSB.

Please note: The CSB is not intended for use in Hotswap Applications.

Requirements:

1. For proper operation, the power supplies being paralleled should be enabled at the same time.

- Out conductors must be of equal length and wire gauge. Separate -Out conductors must be used from each supply to the load, or the use of a "Y" connection to a common point must be used as shown in figure 1. Each leg of the "Y" must have a minimum of a few millivolts of drop in order for proper operation. 50mV to 100mV of drop will provide from 5% to 1% accuracy.
- V1 and -V2 for all Box-to-Box circuits must be connected directly at the negative output power studs or terminals to achieve accurate current sharing.
- D* can be added if redundancy is needed. If redundancy is not required, D* can be replaced with direct wire connections.
- When using D*, the Power input should be connected on the cathode side of the paralleling diodes as shown above.
- Terminate Sense Leads either locally or remotely as shown in figure 1.
- For paralleling more than 2 supplies consult factory for assistance.

CURRENT SHARE BOARD - Optional Feature (contd)

J1 Pinout

Pin	Description
1	Power
2	T1
3	-V1
4	T2
5	-V2
6	No Connection

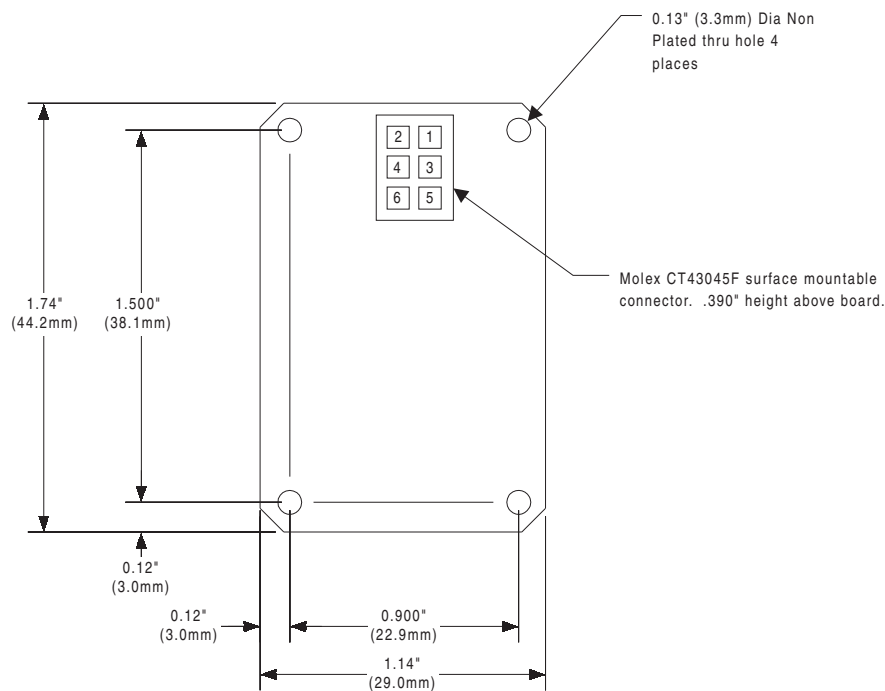

Figure 2. Mechanical Drawing

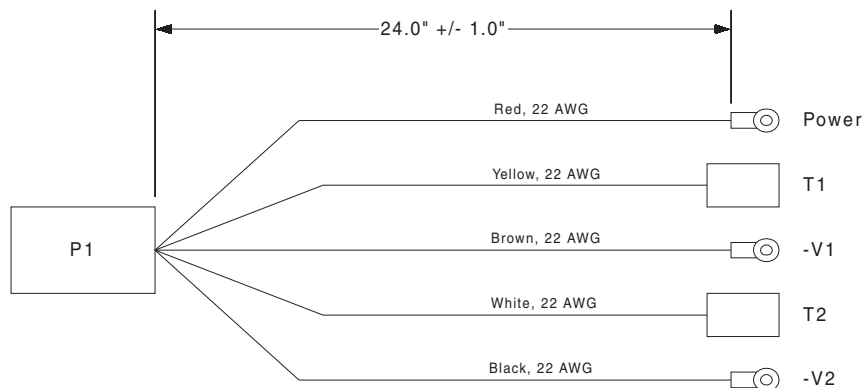

Figure 3. Cable Drawing

Specifications:

1. Power: 2-50Vdc at 5mA maximum.
2. Accuracy: +/- 1mV between -Vout connections.
3. Output current when not trimming up: +/- 1uA (VI-200/J00), +/-5uA (Maxi, Mini Micro series).
4. Use 4 non-plated through holes with standoffs for mounting.
5. CSB01 MUST be used for current sharing VI-200/VI-J00 series converters (VI-200/J00).
6. CSB02 MUST be used for current sharing Maxi, Mini Micro series converters (Maxi, Mini and Micros).

*****PLEASE NOTE, THE CSB IS NOT INTENDED FOR HOTSWAP APPLICATIONS*****

Contact your Regional Applications Engineer at 1-800-927-9474 for additional information.

Low Leakage Version (Available upon request)

If Low Leakage is required, Westcor has a PFC Mini model variant (must be requested). This model enables the user to meet various additional specifications. The advantage of the Low Leakage PFC Mini power supply is in multiple power supply systems that have one AC input. This option will lower the input leakage current for these products to 100 μ A or less (may vary if Maxi, Mini Micro series modules are used. Contact factory for more details.) An additional external EMI filter is typically required.

How Low Leakage is obtained

Low Leakage is obtained with the removal of the "Y" capacitors from within the EMI filter of the PFC Mini *. This reduces the leakage current from the AC input to AC ground (chassis) to below 100 μ A. At the same time, since the "Y" capacitors are a vital component of the EMI filter, without them, the EMI will go up. When this happens, the unit will no longer meet Westcor's published specifications for conducted EMI. In order to reduce the EMI to within an acceptable limit, an additional external EMI filter is required. All safety agency certifications for the PFC Mini remains intact**. Contact Applications Engineering for more information.

** Please note that the PFC Mini (including Low Leakage version) is NOT UL 2601 compliant.

Low output ripple

If output ripple of 10mV p-p or 0.15% (whichever is greater) is required, a PFC Mini with RAM modules can be configured if the maximum output power per output does not exceed 100W. If this configuration is required, please contact wcmarketing@vicr.com to have it configured since this option is currently not available using the online configuration tool (VSPOC).

If there are space restrictions, an external RAM/uRAM can also be used.

Office environment fan

A PFC Mini using an office environment fan is available. Please note that the maximum output power for this version is 1,200W. The maximum output power per slot is limited to 500W.

Molex Connector limitation

Please note that those PFC Mini configurations that use Molex connectors are limited to 9A/pin (27A per output). This is a Molex connector limitation, NOT a module power limitation. Westcor's online configuration tool (VSPOC) will not provide a PFC Mini solution for requirements that exceed the 27A limitation.

Notes

VICOR GLOBAL OFFICES

USA

Vicor Corporation, Corporate Headquarters

25 Frontage Road
Andover, MA 01810
Tel: 800-735-6200
Tel: 978-470-2900
Fax: 978-475-6715

Vicor Corporation

377 E. Butterfield Road
Suite 201
Lombard, IL 60148
Tel: 630-769-8780
Fax: 630-769-8782

Vicor, Westcor Division

560 Oakmead Parkway
Sunnyvale, CA 94085
Tel: 408-522-5280
Fax: 408-774-5555

EUROPE

Vicor France

Tel: 33-1-3452-1830
Free Phone
France Only:
0800 419 419
Fax: 33-1-3452-2830
Email: vicorfr@vicr.com

Vicor Italy

Tel: +39-02-2247-2326
Free Phone *Italy Only:*
800-899-677
Fax: +39-02-2247-3166
Email: vicorit@vicr.com

Vicor Germany

Tel: +49-89-962439-0
Free Phone
Germany Only:
0800 018 29 18
Fax: +49-89-962439-39
Email: vicorde@vicr.com

Vicor U.K.

Tel: +44-1276-678-222
Free Phone *UK Only:*
0800-980-8427
Fax: +44-1276-681-269
Email: vicoruk@vicr.com

ASIA-PACIFIC

Vicor Hong Kong

Tel: +852-2956-1782
Fax: +852-2956-0782

Vicor Japan Co., Ltd.

Tel: 81-3-5487-3880
Fax: 81-3-5487-3885

For more information about this or other Vicor products, or for assistance with component-based power system design, contact the Vicor office nearest you. Westcor's product line includes:

LOPAC FAMILY:

- PFC MicroS
- PFC Micro
- PFC Mini

MEGAPAC FAMILY:

- PFC MegaPAC
- PFC MegaPAC (Low Noise/High Power)
- 4kW MegaPAC
- PFC MegaPAC-EL (Low Noise)
- Mini MegaPAC
- 4kW MegaPAC-EL (Low Noise)
- PFC MegaPAC (High Power)
- Autoranging MegaPAC
- ConverterPACs

OTHERS:

- FlatPAC-EN

Configure your own Westcor power supply online using the VSPOC configurator tool available on vicorpower.com!

Information furnished by Vicor is believed to be accurate and reliable. However, no responsibility is assumed by Vicor for its use. No license is granted by implication or otherwise under any patent or patent rights of Vicor. Vicor components are not designed to be used in applications, such as life support systems, wherein a failure or malfunction could result in injury or death. All sales are subject to Vicor's Terms and Conditions of Sale, which are available upon request.

Specifications are subject to change without notice. *The latest data is available on the Vicor website at vicorpower.com*



www.vicorpower.com