

7 A Active EMI Filter for 48 Vdc Bus

Description

The QPI-4 active EMI filter attenuates conducted common-mode (CM) and differential-mode (DM) noise over the CISPR22 frequency range of 150 kHz to 30 MHz. The product is designed for use on a 48 Vdc bus (36 – 76 Vdc). The QPI-4's 7 A rating supports multiple DC-DC converter loads up to a PCB temperature of 60°C. At a 100°C PCB temperature the QPI-4 supports 6 A loads. Designed for the telecom and ITE bus range, the QPI-4 supports the PICMG® 3.0 specification for filtering system boards to the EN55022 Class B limits.

In comparison to passive solutions, the use of active filtering reduces the volume of the common-mode choke, providing a low profile, surface mount device. Smaller size saves valuable board real estate and the reduced height enhances airflow in blade applications.

The QPI-4 is available in a 25 x 25 x 4.5 mm SiP (System-in-Package) with LGA mounting. QPI-4-EVAL1 kits are available for testing the QPI-4. The evaluation board has a mounted QPI-4 with screw terminals for quick in-circuit testing.

Check picorpower.com for the QPI-4-EVAL1 evaluation board and the QPI-AN1 Application Note.

Features

- >40 dB CM attenuation at 250 kHz
- >70 dB DM attenuation at 250 kHz
- 80 Vdc (max input)
- 7 A rating
- 100 Vdc surge 100 ms
- 1,500 Vdc hipot hold off to shield plane
- 25 x 25 x 4.5 mm SiP (System-in-Package)
- Low profile LGA package
- -40° to +100°C PCB temperature (See Fig. 5)
- Active filtering reduces volume and height
- Efficiency >99% at full load
- Connect in series for higher attenuation
- TÜV approved

Applications

- ATCA blades
- Telecom base stations
- IBA & distributed power

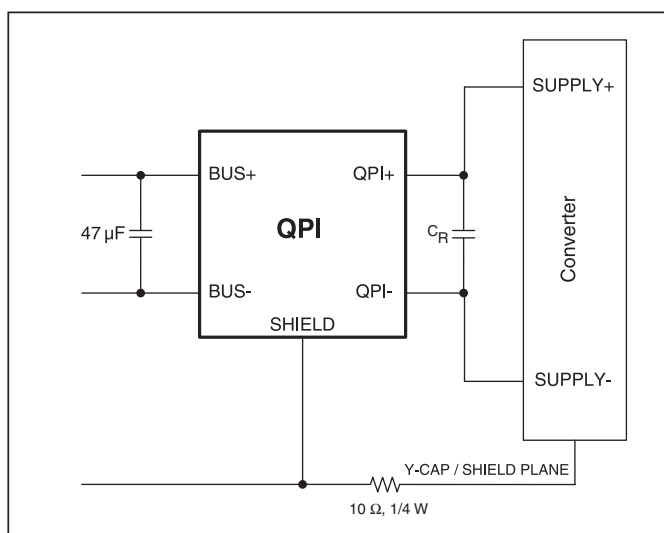

Figure 1 – Typical Application; QPI basic input bus filter circuit. Read important note on page 4 for Layout and Circuit Considerations.

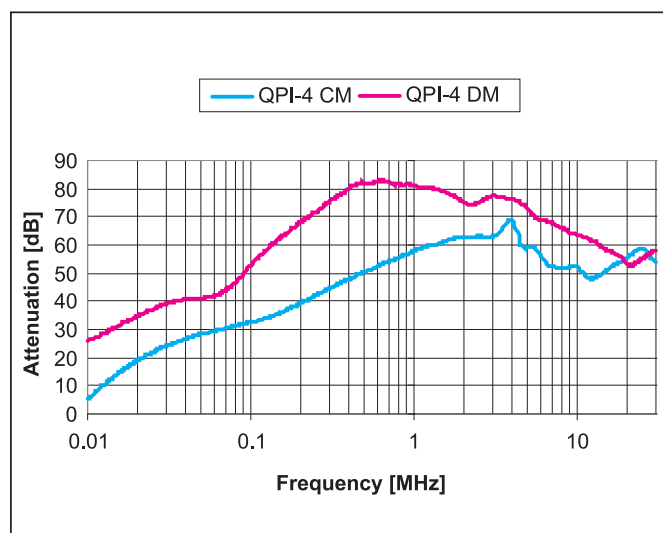

Figure 2 – QPI Performance; Attenuation curves showing common-mode and differential-mode attenuation.

Absolute Maximum Ratings – Exceeding these parameters may result in permanent damage to the product.

Pins	Parameter	Notes	Min	Max	Units
BUS+ to BUS-	Input voltage	Continuous	-80	80	Vdc
BUS+ to BUS-	Input voltage	100ms transient	-100	100	Vdc
BUS+/BUS- to shield plane	BUS inputs to shield hipot	Per test std.		+/-1500	Vdc
QPI+ to QPI-	Input to output current	10 seconds @ 25°C		10	Adc
Package	Power dissipation	VBUS = 48 V, IBUS = 7 Adc, 60°C		2.0	W
Package	Operating temperature	PCB to QPI Interface	-40	100	°C
Package	Thermal resistance	Free air		50	°C/W
Package	Junction temperature	Internal @ P _{dmax} and 15°C/W		130	°C
Package	Thermal resistance	PCB layout ⁽¹⁾		15	°C/W
Package	Storage temperature		-40	125	°C
Package	Re-flow temperature	20 second exposure @ ⁽²⁾		212	°C
All Pins	ESD	HBM		+/-2	kV

Note 1: Refer to Figures 9 & 10 for PCB layout guidelines to achieve this thermal resistance when re-flowed onto the PCB.

Note 2: RoHS compliant product maximum peak temperature is 245°C for 20 seconds

Electrical Characteristics – Parameter limits apply over the operating temp. range unless otherwise noted.

Parameter	Notes	Min	Typ	Max	Units
BUS+ to BUS- input range	Measured at 7 A ⁽³⁾	30		80	Vdc
BUS+ to QPI+ voltage drop	Measured at 7 A ⁽³⁾			-120	mVdc
BUS- to QPI- voltage drop	Measured at 7 A ⁽³⁾			30	mVdc
Common-mode insertion loss	VBUS = 48 V frequency = 500 kHz		42		dB
Differential-mode insertion loss	VBUS = 48 V frequency = 500 kHz		72		dB
Input bias current at 80 V	Input current from BUS+ to BUS-		8		mA

Note 3: Refer to Figure 5 for current derating curve.

Pad Description

Pin Number	Name	Description
12, 13, 14	BUS+	Positive bus voltage
1, 15, 16	BUS-	Negative bus potential
7, 8, 9	QPI+	Positive input to the converter
2, 3, 4	QPI-	Negative input to the converter
5, 6	SHIELD	The shield connects to the converter shield and Y capacitor common point through RY.
10	THERM1	Internal connection must be electrically floating but maximize copper landing for heat sinking.
11	THERM2	Internal connection must be electrically floating but maximize copper landing for heat sinking.

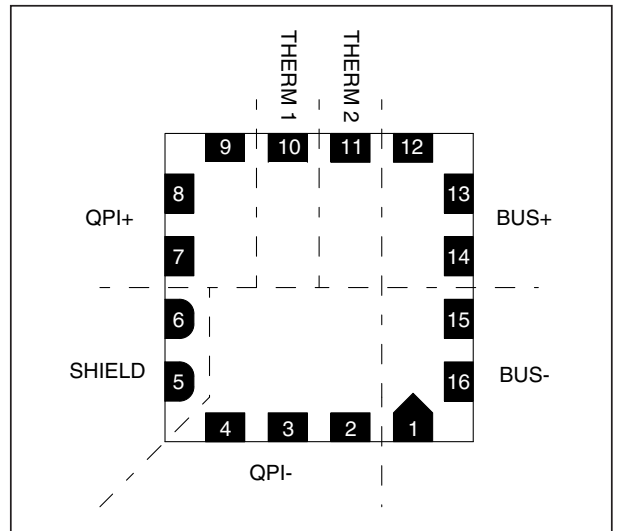

Applications Information

The QPI-4 is an active EMI filter providing conducted common-mode and differential-mode attenuation from 150 kHz to 30 MHz. The QPI-4 attenuates noise at all frequencies covered by EN55022. Designers should be aware that to select and qualify an EMI filter they must test the filter in their equipment under the set up and conditions specified in the EMI standards that they are trying to meet.

Filter performance is highly dependent on several factors and cannot be derived from the attenuation curves shown in Figure 2 alone. Performance is a complex function of filter element impedances and noise source impedances, which vary in magnitude and phase over the frequency spectrum. Measurements should be made in consultation with in-house compliance testing or an independent EMI test facility.

Test Example

Figures 3 and 4 show the before and after plots of a DC-DC converter noise profile to demonstrate the performance of the QPI-4. The plots were taken using the standard measurement technique and set up defined in CISPR22. The results show the total noise spectrum for a standard DC-DC converter under load compared to the EN55022 Class B Quasi-peak detection limit.

The resulting plot in Figure 4 shows the QPI-4 is effective in reducing the total conducted noise spectrum measured pre-filter to well below the EN55022 Class B Quasi-peak detection limit.

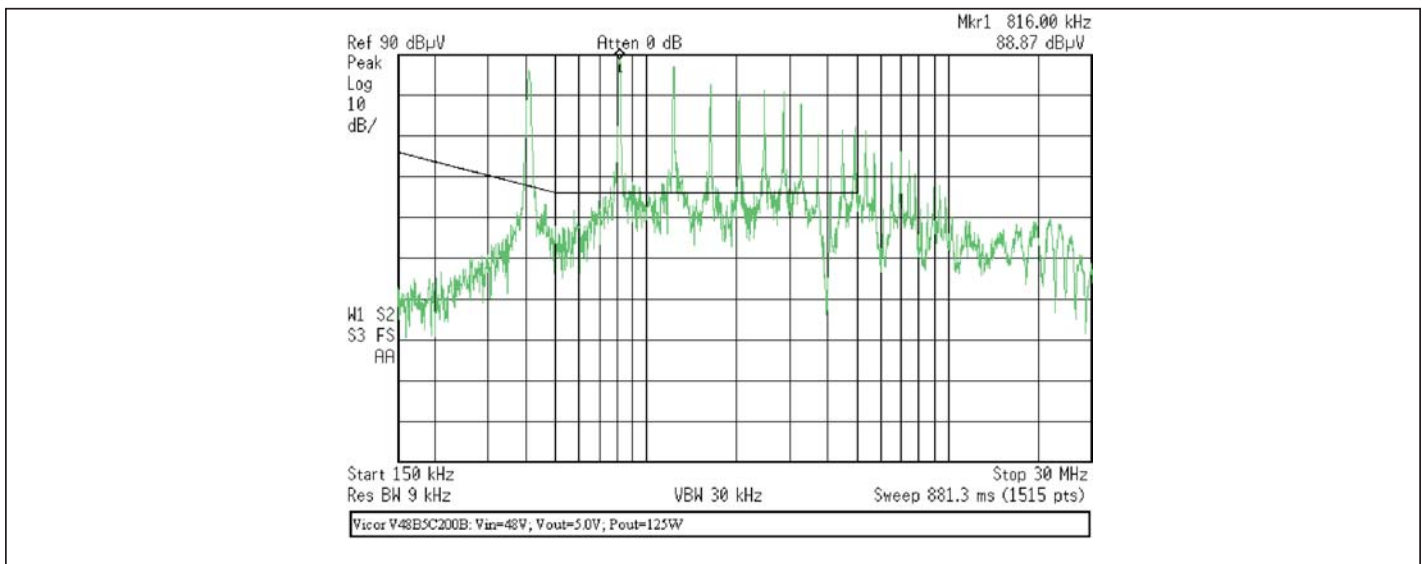

Figure 3 – Conducted EMI profile of a DC-DC Converter without filter.

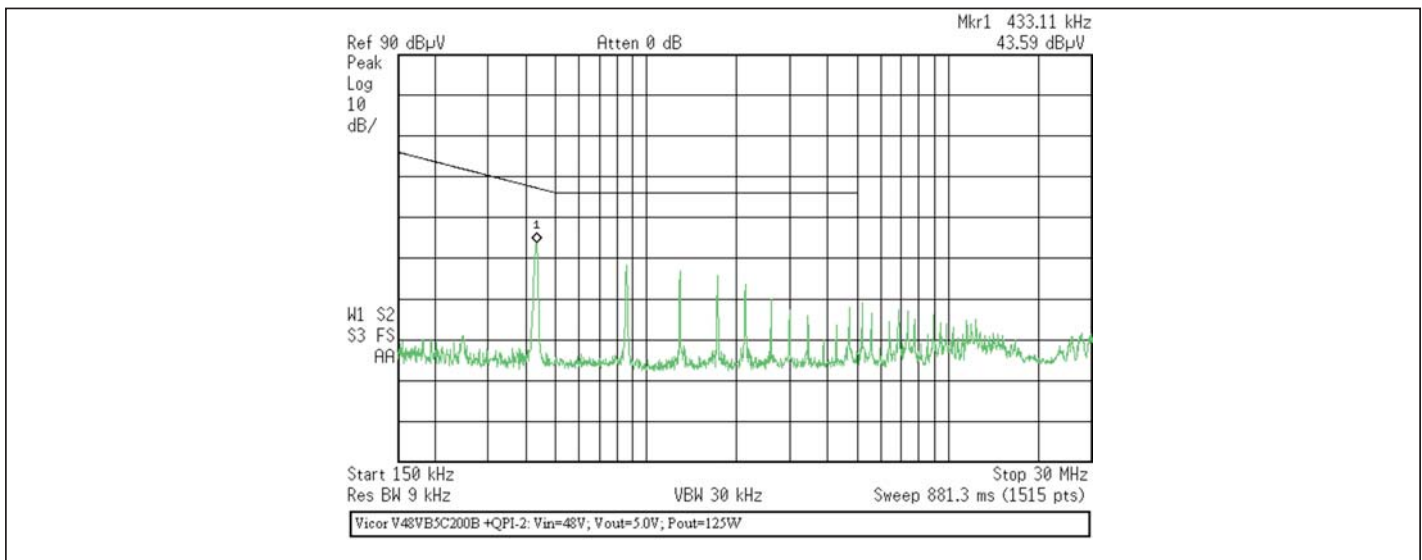

Figure 4 – Conducted EMI profile of a DC-DC Converter with QPI-4.

Layout and Circuit

Application of the QPI-4 requires PCB layout practices similar to those used with passive EMI filters. The circuit in Figure 6 and the PCB layout in Figures 9 & 10 should be used as a design guide to ensure successful application of the QPI-4. Refer to the application note QPI- AN1 for additional PCB layout recommendations.

Note: For optimum performance of the QPI, it is critical to connect the QPI's shield plane (pins 5 & 6) to the converter EMI shield plane (common point of C1-C4 "Y" capacitors) thru RY as shown in Figure 6. If the safety earth-ground connection (chassis or case) is connected in the power conversion section of the PCB it should be at the input bus of the QPI's shield plane, shown as the optional connection in Figure 6. Connecting the converter EMI shield plane directly to chassis ground may degrade the QPI's attenuation performance. The typical value for RY is 10 Ω . The recommended part is a 5% tolerance SMT1206 or similarly rated 0.25 W thru-hole resistor.

Some systems may require the converter positive or negative input or an output "terminal" to be connected to PE (Protective Earth) ground for safety or other considerations. When using the QPI in this situation this "terminal" must be connected to the converter shield plane created in the PCB layout under the converter. Because the PE earth path may pass excessive current under a fault condition the resistance of this path may be limited to a low resistance value. To meet the resistance requirement without degrading filter performance Ry can be replaced by a 4.7uH inductor rated for the fault current condition maintaining low power dissipation during a fault until the protection device clears.

QPIs will filter multiple DC-DC converters up to the maximum current rating. The schematic in Figure 7 shows the required circuit for multiple DC-DC converters. The shield plane should be added under each converter as a common EMI Shield. Note that only a single RY is required in a multiple converter configuration.

If higher attenuation is required, QPIs can be connected in series. Figure 8 shows the proper schematic for QPIs in series. Note that only one RY is required in this configuration.

The QPI can also be used to filter embedded or "down" converters made up of discrete components. Where ever possible a shield plane and Y-capacitor decoupling should be included in the embedded converter design. Follow the circuit and layout recommendations for a brick converter shown in Figures 7, 9 & 10.

Thermal Considerations

The current derating curve shown in Figure 5 should be used when the PCB temperature in close proximity of the QPI-4 exceeds 60°C. For example, the QPI-4 will support up to 6.5 A of current or 312 W from a 48 Vdc bus at an 80°C interface temperature. Temperature should be measured at the PCB interface to the QPI-4 on the Bus +/- pads or the QPI+/- pads. Refer to Figures 9, 10 & 12 for PCB layout recommendation.

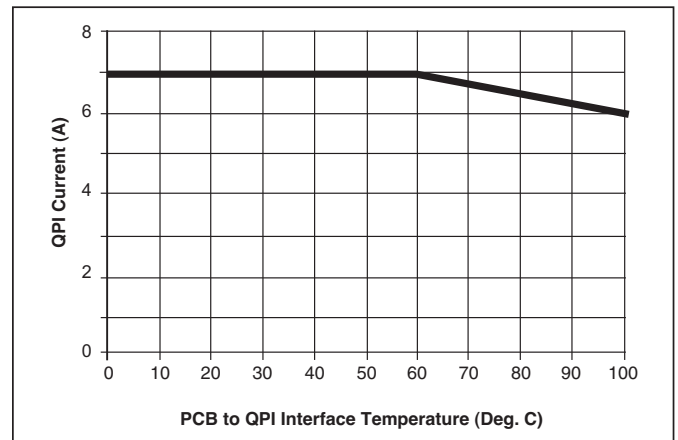

Figure 5 – QPI-4 current derating curve.

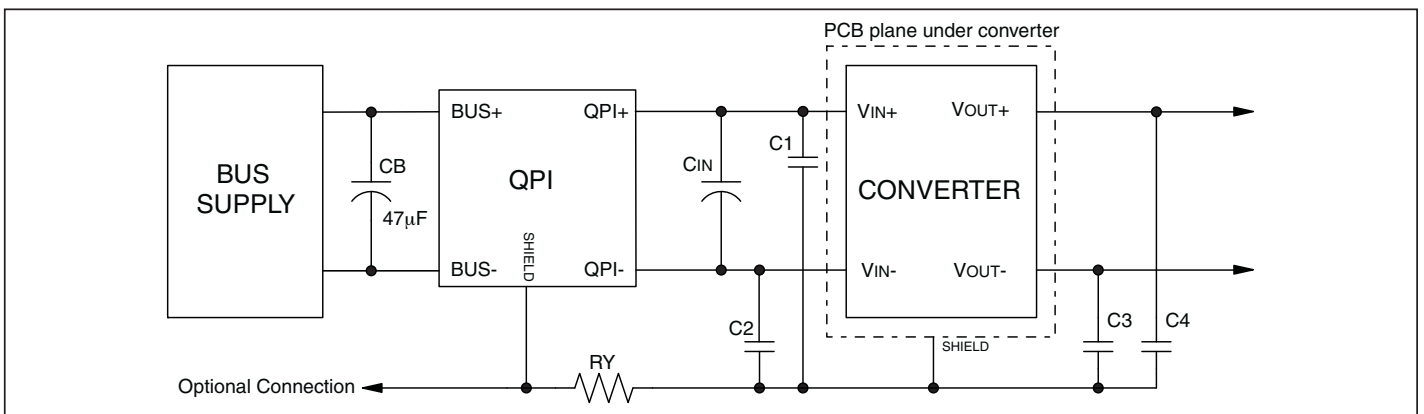

Figure 6 – Recommended schematic for QPI. Values of C_{IN} and C1-C4 should be the values recommended by the converter manufacturer. If the manufacturer does not specify a value for the Y-capacitors use 4.7nF. R_y=10 Ω , 1/4 W.

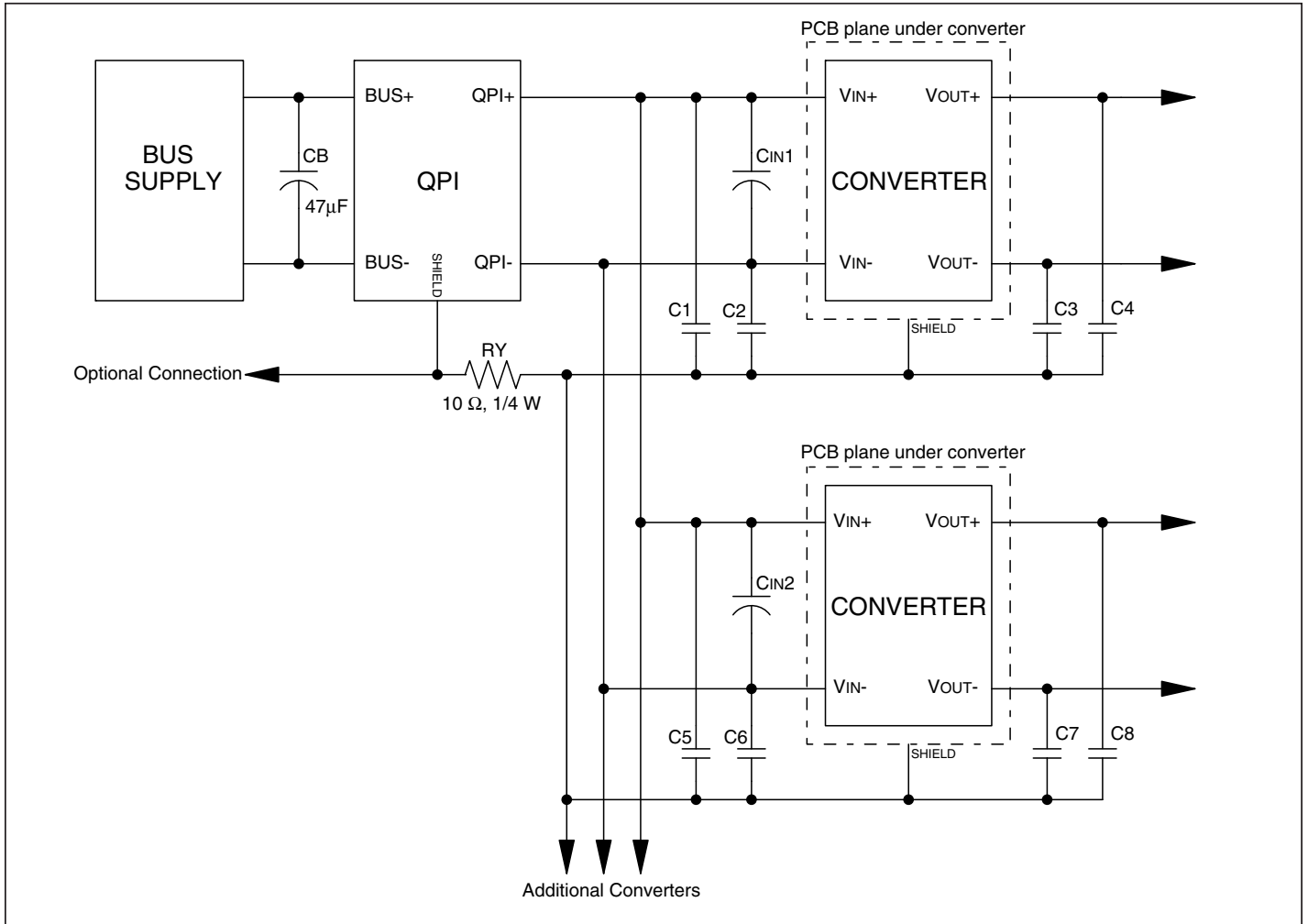

Figure 7 – Schematic for supporting multiple DC-DC converters. Note only a single RY is required. Use values recommended by converter manufacturer for CIN and Y-capacitors C1-C8.

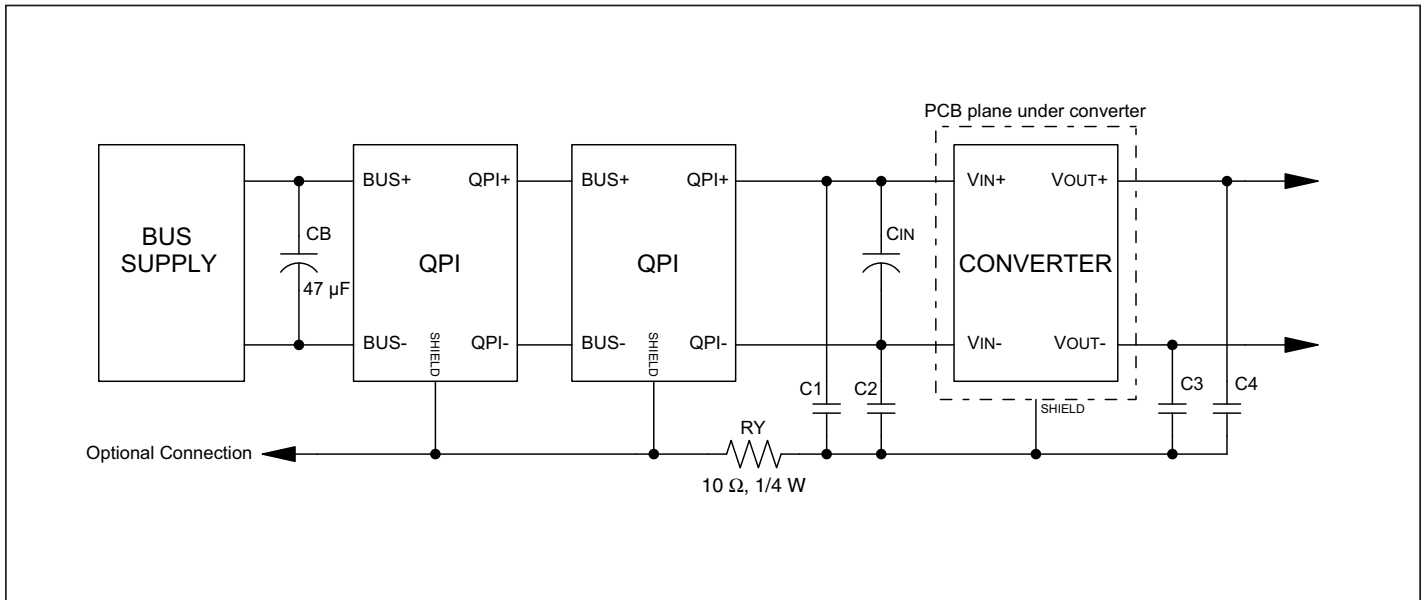

Figure 8 – Series connection of QPI for higher attenuation.

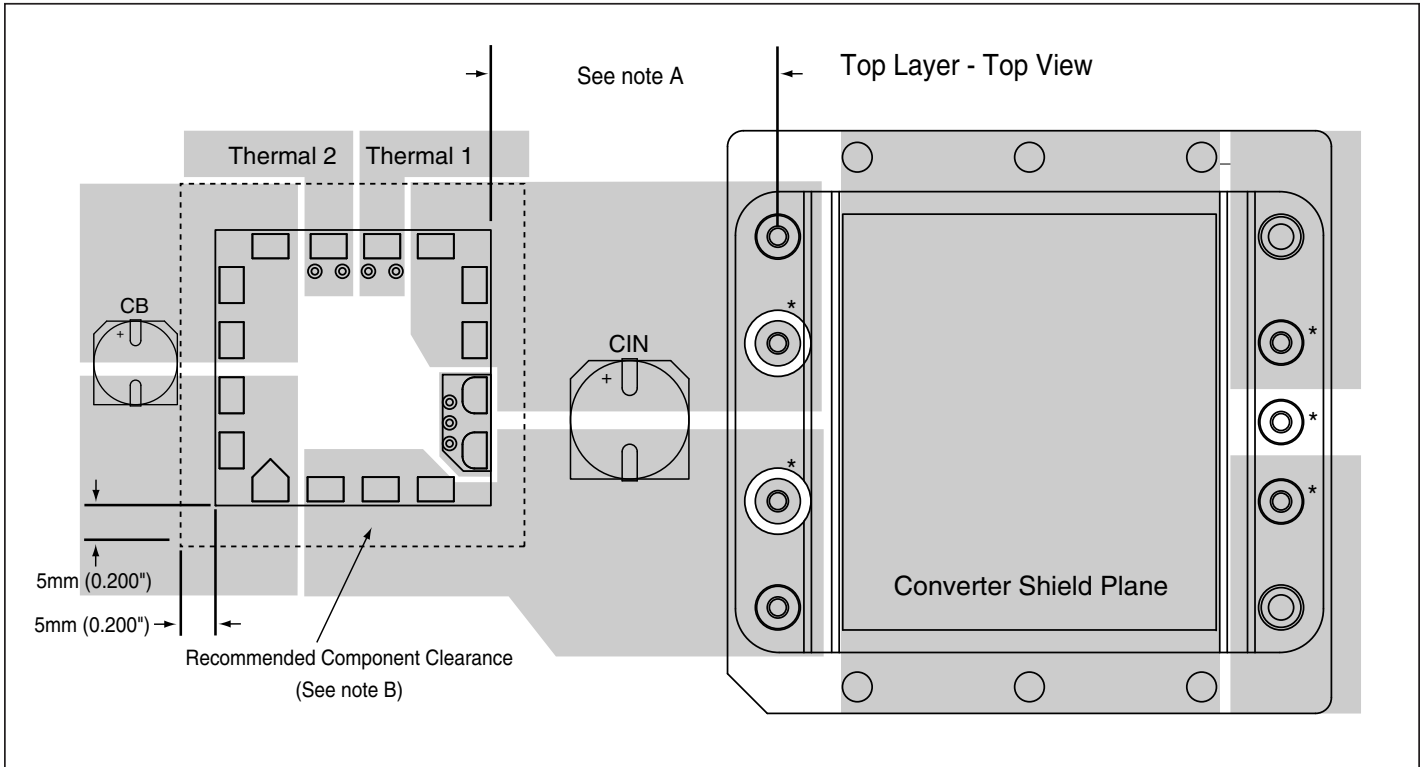

Figure 9 – Recommended layout for top layer of PCB. Pattern shows optional pins (*) dependent on converter used in design. (Actual size with half brick footprint)

Note A: Some converters may radiate energy past the QPI into the input bus degrading noise reduction of the filter. To minimize the potential for this effect use a maximum feasible distance between the QPI and the converter in the layout. The input filter and any bulk hold up capacitors should be placed in this area.

Note B: Hako de-soldering nozzle model no. A1137 and appropriated temperature controller can be used for removing and re-soldering SiP packages. Clearance around the SiP is a keep out zone for components as noted by the dashed line to use this tool. Components taller than 10 mm (0.400") require 15 mm (0.600") clearance from the SiP package edge.

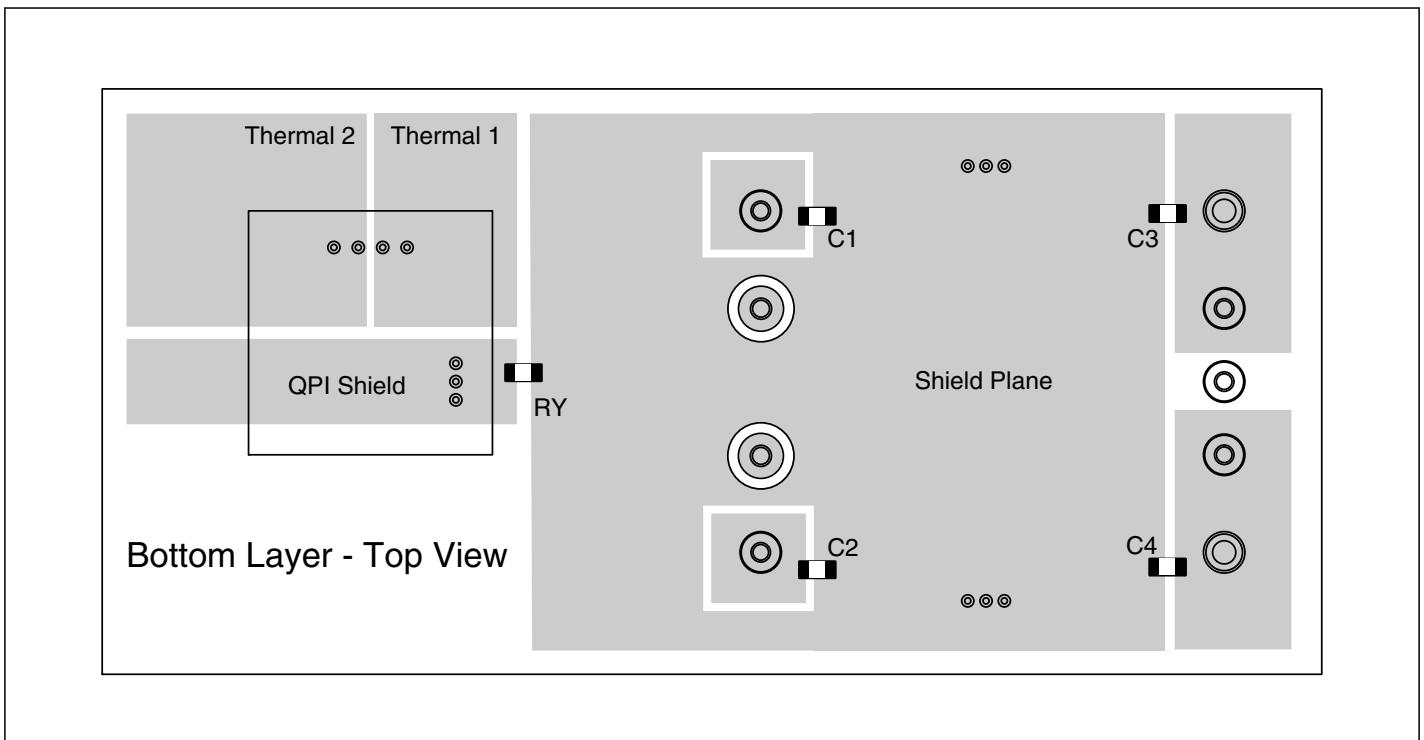

Figure 10 – Recommended layout for bottom layer of PCB. Note location of RY.

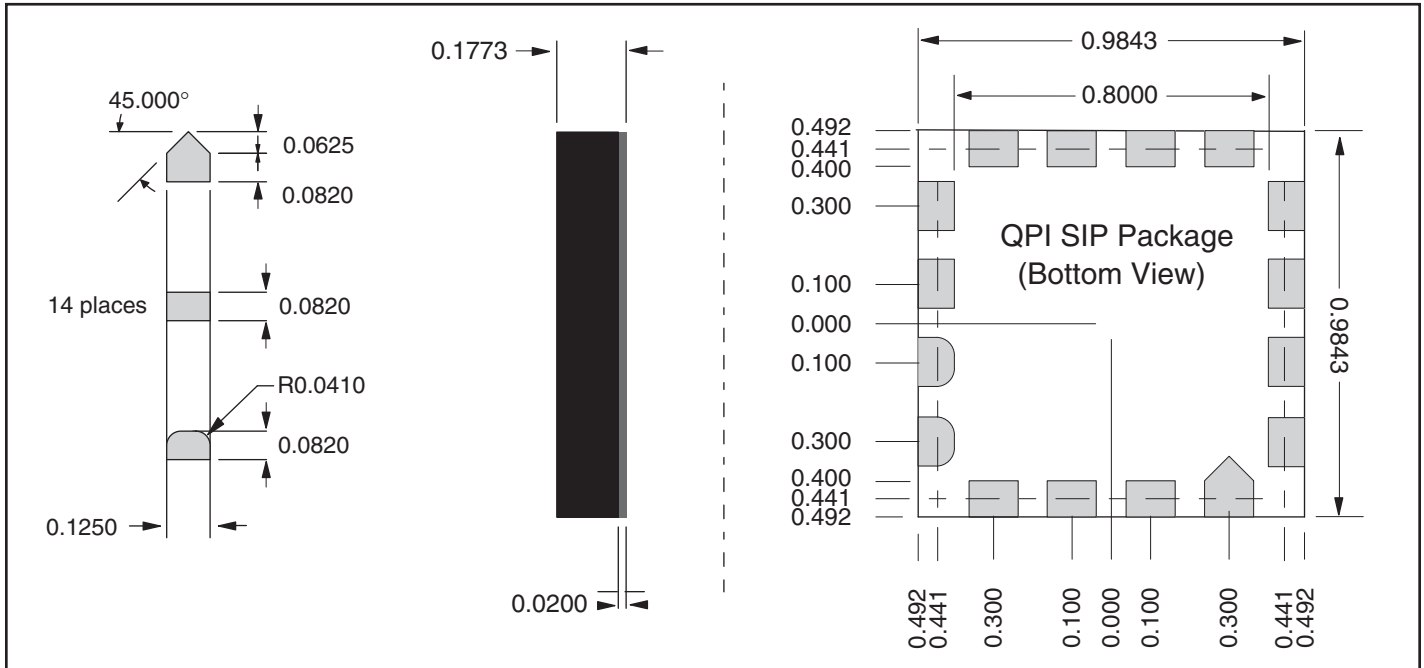

Figure 11 – QPI package dimensions and pad locations.

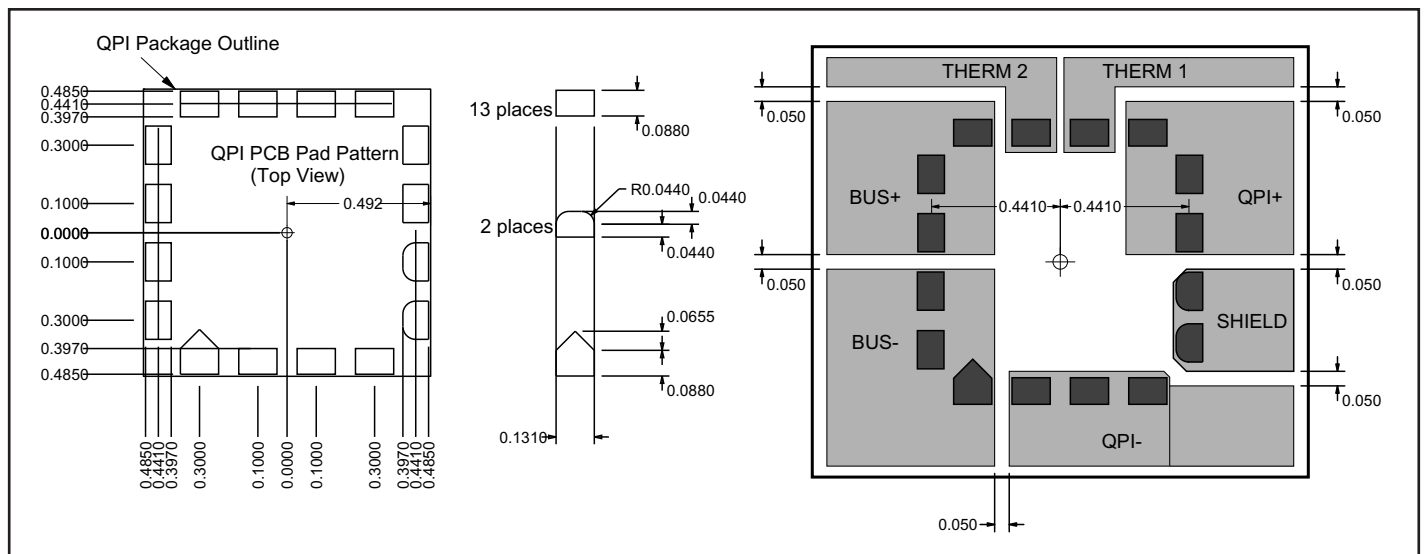

Figure 12 – Recommended PCB solder mask dimensions and layout. Use 1.3mm clearance around shield pads 5 & 6 to adjacent lands. See Figures 9 & 10 for recommended connection layouts.

Post Solder Cleaning

Picor lidded QP SIPs are not hermetically sealed and must not be exposed to liquid, including but not limited to cleaning solvents, aqueous washing solutions or pressurized sprays.

When soldering, it is recommended that no-clean flux solder be used, as this will insure that potentially corrosive mobile ions will not remain on, around, or under the module following the soldering process.

For applications requiring water wash compatibility the “-01” open frame version should be used.

Ordering Information

Part Number	Description
QPI-4LZ	QPI-4 LGA Package, RoHS Compliant
QPI-4LZ-01	QPI-4 LGA, RoHS Compliant Open Frame Package

Vicor's comprehensive line of power solutions includes high-density AC-DC & DC-DC modules and accessory components, fully configurable AC-DC & DC-DC power supplies, and complete custom power systems.

Information furnished by Vicor is believed to be accurate and reliable. However, no responsibility is assumed by Vicor for its use. No license is granted by implication or otherwise under any patent or patent rights of Vicor. Vicor components are not designed to be used in applications, such as life support systems, wherein a failure or malfunction could result in injury or death. All sales are subject to Vicor's Terms and Conditions of Sale, which are available upon request.

Specifications are subject to change without notice.



Vicor Corporation

25 Frontage Road, Andover, MA, USA 01810
Tel: 800-735-6200 Fax: 978-475-6715

Email

Sales Support: vicorexp@vicorpower.com
Technical Support: apps@vicorpower.com